

	EN	DE	ES	FR	IT	NL	PL	CS
DH	Daylight height	Lichte Höhe	Altura del hueco	Hauteur de baie libre	Luce passaggio altezza	Dagmaat hoogte	Wysokość otworu	Světlá výška otvoru
DW	Daylight width	Lichte Breite	Ancho del hueco	Largeur de baie libre	Luce passaggio larghezza	Dagmaat breedte	Szerokość otworu	Světlá šíře otvoru
HR	Headroom	Sturzhöhe	Espacio libre	Hauteur du linteau	Architrave	Bovenruimte	Nadproža	Nadpraží
SH	System height	System Höhe	Altura del sistema	Hauteur du système	Altezza sistema	Systeemhoogte	Wysokość systemu	Výška systému
CH	Ceiling height	Deckenhöhe	Altura del techo	Hauteur	Altezza veletta	Plafondhoogte	Wysokość sufitu	Výška stropu
GW	Garage width	Garageninnenmaß	Ancho del garaje	Largeur du garage	Larghezza garage	Garagebreedte	Szerokość garażu	Šíře garáže
PTH	Pass through height	Freie Durchfahrthöhe	Alto del paso	Hauteur de passage libre	Altezza netta passaggio	Doorrijhoogte	Przejdz przez wzrost	Průjezdová výška
PTW	Pass through width	Freie Durchfahrtsbreite	Ancho del paso	Largeur de passage libre	Larghezza netta passaggio	Doorrijbreedte	Przepuść szerokość	Průjezdová šíře
PH	Panel height	Paneelhöhe	Altura del panel	Hauteur de panneaux	Altezza pannello	Paneelhoogte	Wysokość panelu	Výška panelu
PW	Panel width	Paneelbreite	Ancho del panel	Largeur de panneaux	Larghezza pannello	Paneelbreedte	Szerokość panelu	Šířka panelu
L	Length	Länge	Longitud	Longueur	Lunghezza	Lengte	Długość	Délka

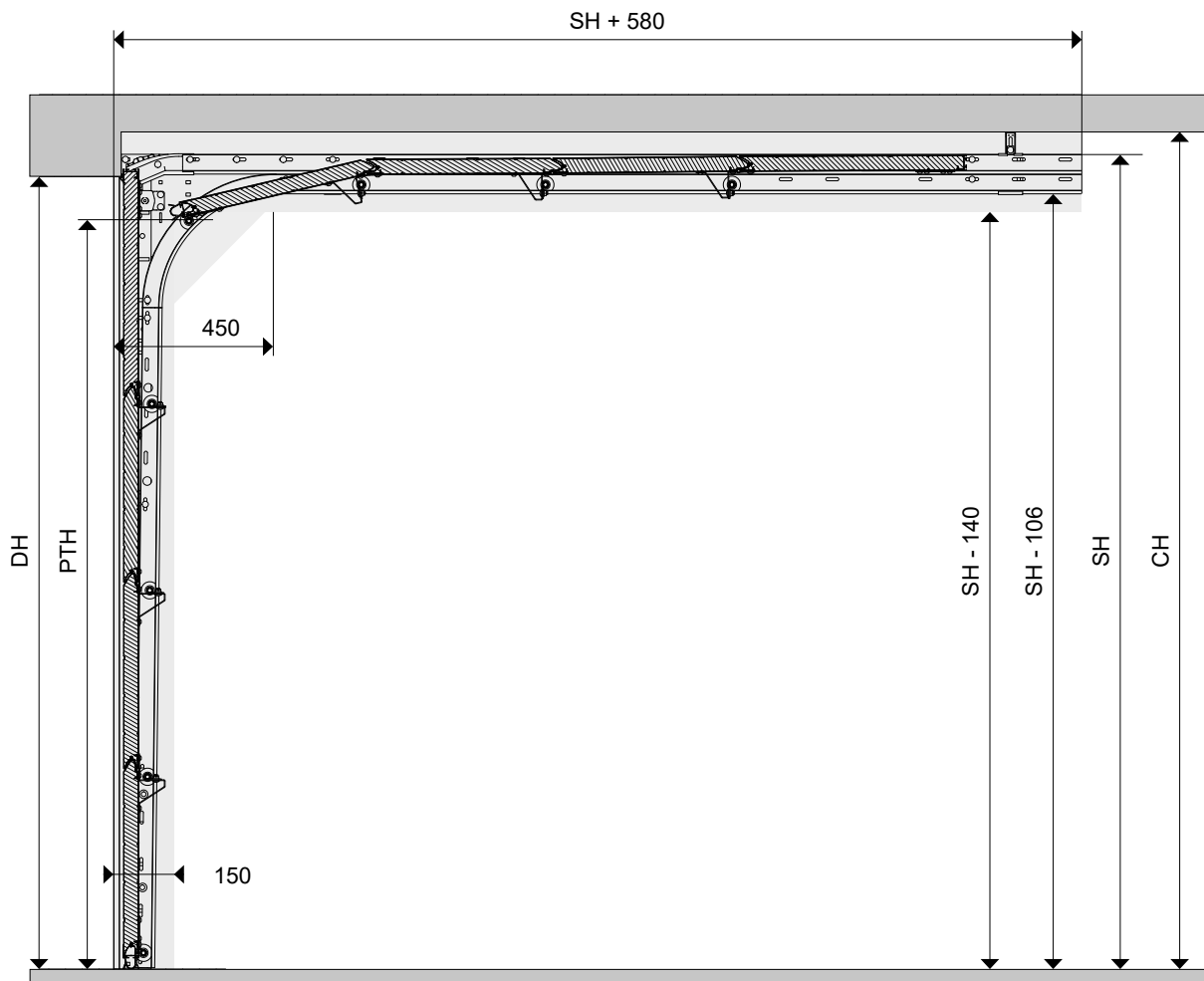

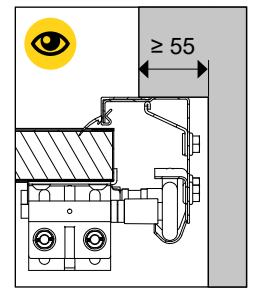
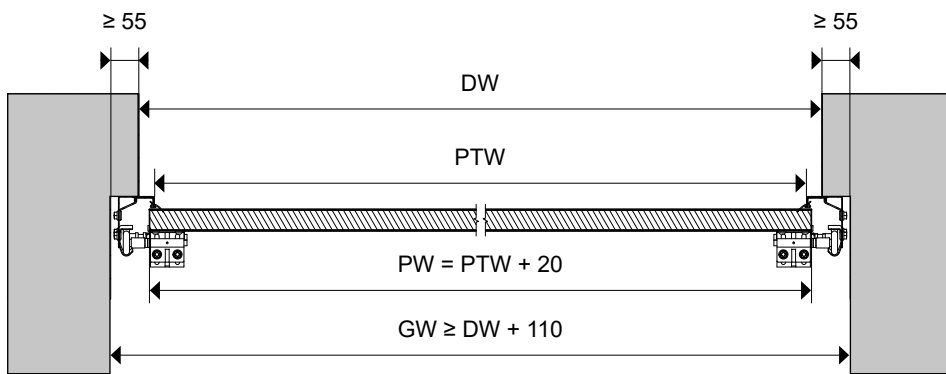
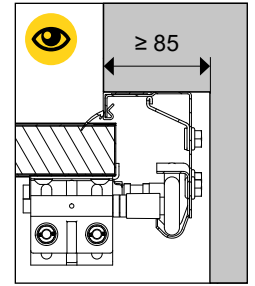
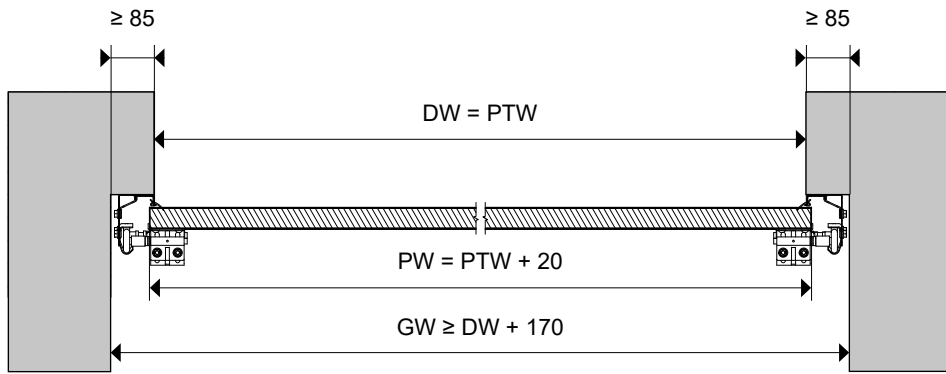

	Standard Estándar Standardowy Standardně	Minimum Mínimo Minimální	 22005X-XXXX
	$CH \geq SH + 30$ $PTH = SH - 235^*$	$HR \geq 90$ $SH = DH + 60$	$HR \geq 60$ $SH = DH + 30$
	$CH \geq SH + 60$ $PTH = SH - 70$	$HR \geq 120$ $SH = DH + 60$	$HR \geq 90$ $SH = DH + 30$
			$HR \geq 25$ $SH = DH - 5$
			$HR \geq 55$ $SH = DH - 5$

- * (EN) With manual door stop (280020): $PTH = SH - 70$
- * (DE) Mit handbetätigtem Türstopper (280020): $PTH = SH - 70$
- * (ES) Con parada manual de la puerta (280020): $PTH = SH - 70$
- * (FR) Avec butée de porte, pour porte manuel: (280020): $PTH = SH - 70$
- * (IT) Manuale con stop porta (280020): $PTH = SH - 70$
- * (NL) Met manuele deurstop (280020): $PTH = SH - 70$
- * (PL) Z ręcznym zatrzymaniem drzwi (280020): $PTH = SH - 70$
- * (CS) Manuální vratová zarážka (280020): $PTH = SH - 70$

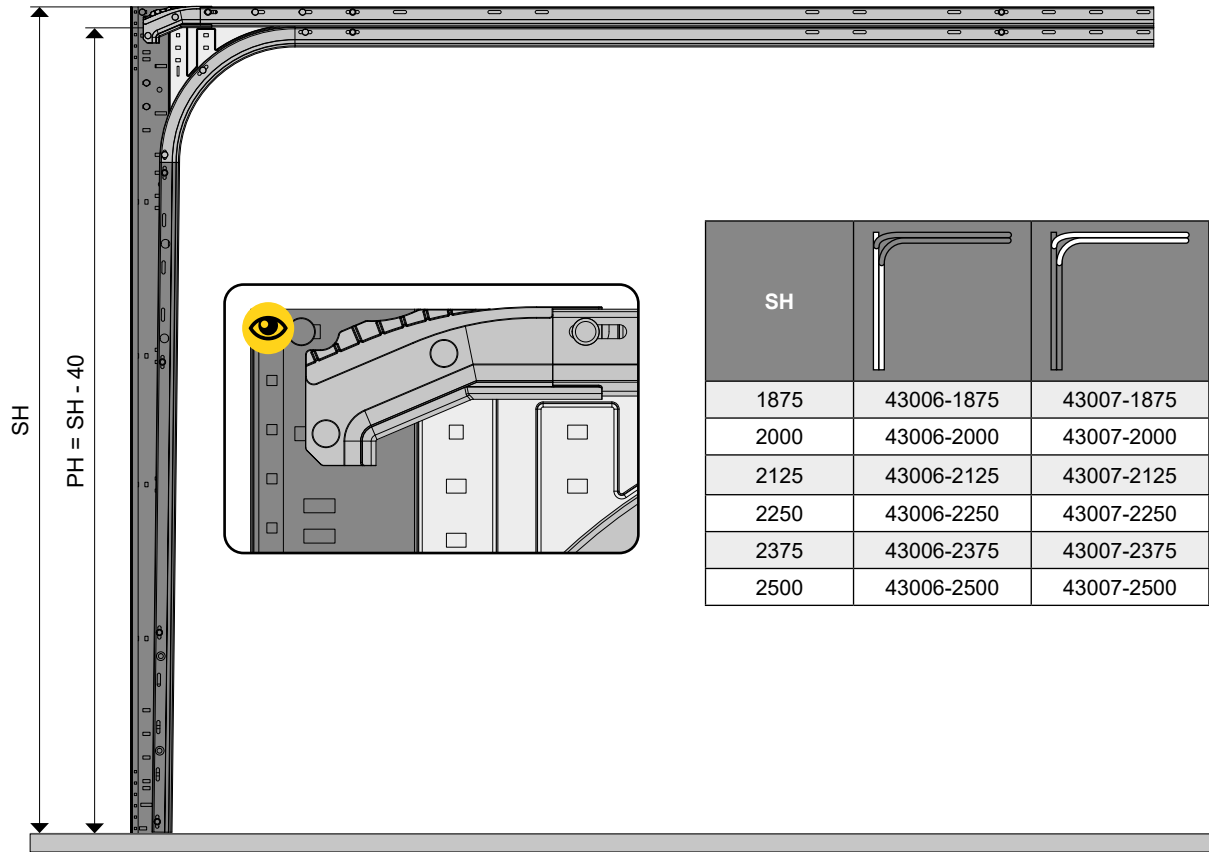

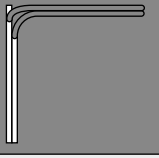
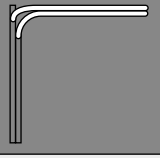
SH		
1875	43006-1875	43007-1875
2000	43006-2000	43007-2000
2125	43006-2125	43007-2125
2250	43006-2250	43007-2250
2375	43006-2375	43007-2375
2500	43006-2500	43007-2500

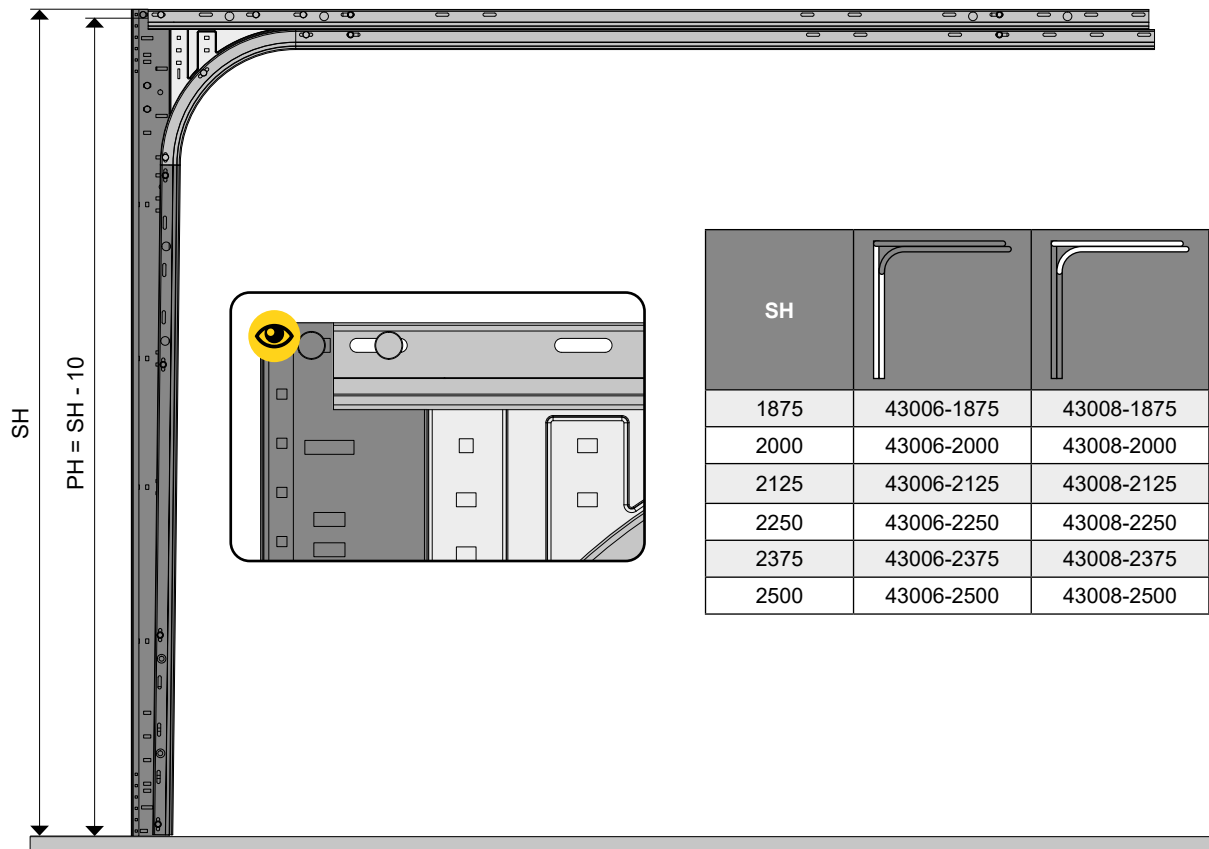

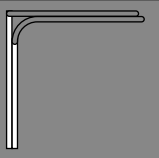
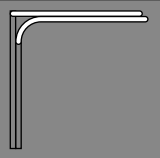
SH		
1875	43006-1875	43008-1875
2000	43006-2000	43008-2000
2125	43006-2125	43008-2125
2250	43006-2250	43008-2250
2375	43006-2375	43008-2375
2500	43006-2500	43008-2500

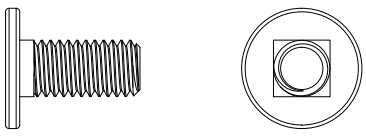
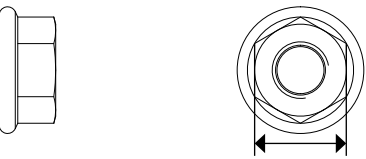
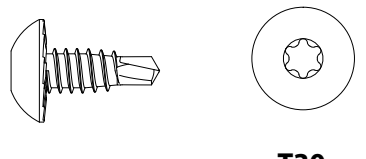
<p>A 14024</p>  <p>M8 x 10,5 Ø 17 mm</p>	<p>B 14023</p>  <p>M8 x 17 Ø 17 mm</p>
<p>C 14022</p>  <p>M8 13 mm</p> <p>10 Nm</p>	<p>D 150113</p>  <p>ST6,3 x 16 T30 Ø 14 mm</p> <p>10 Nm</p>

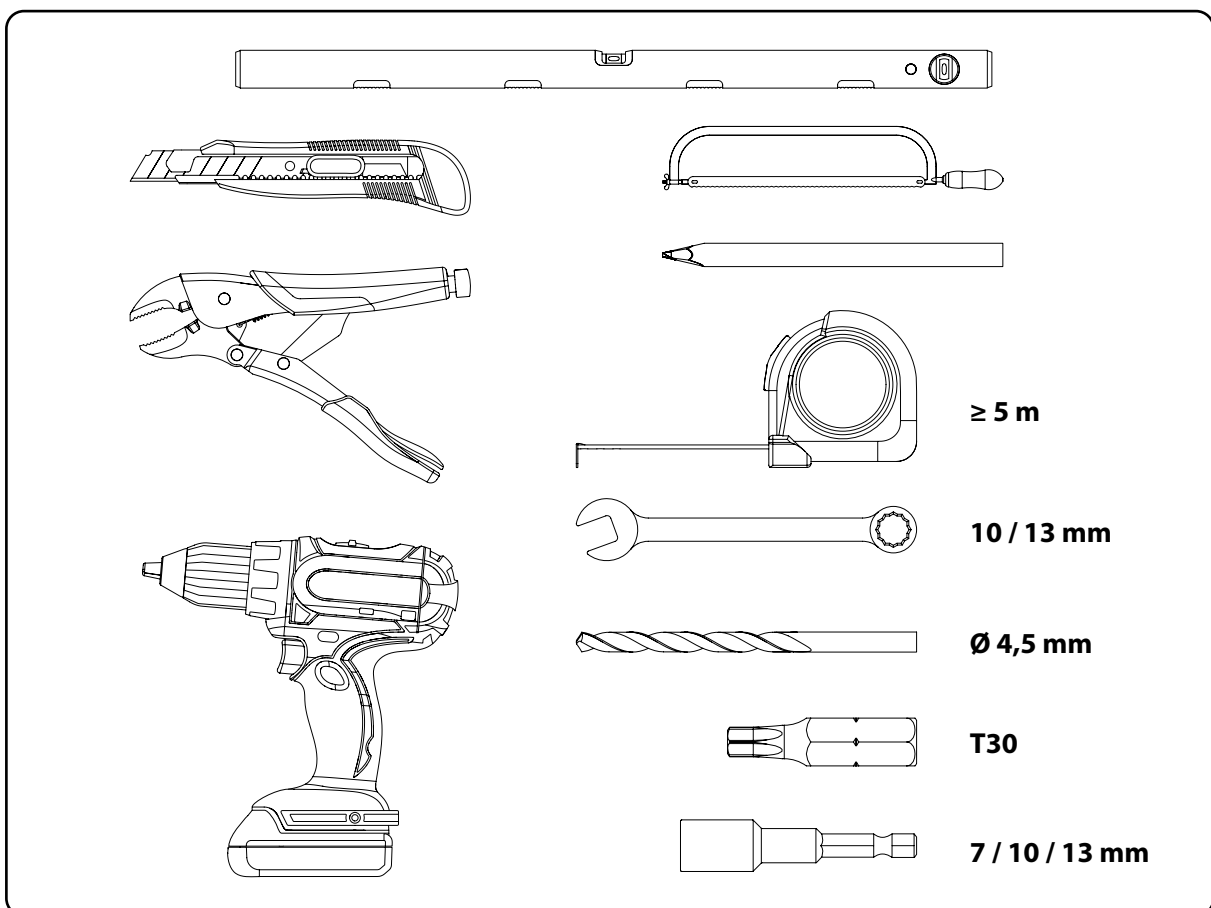

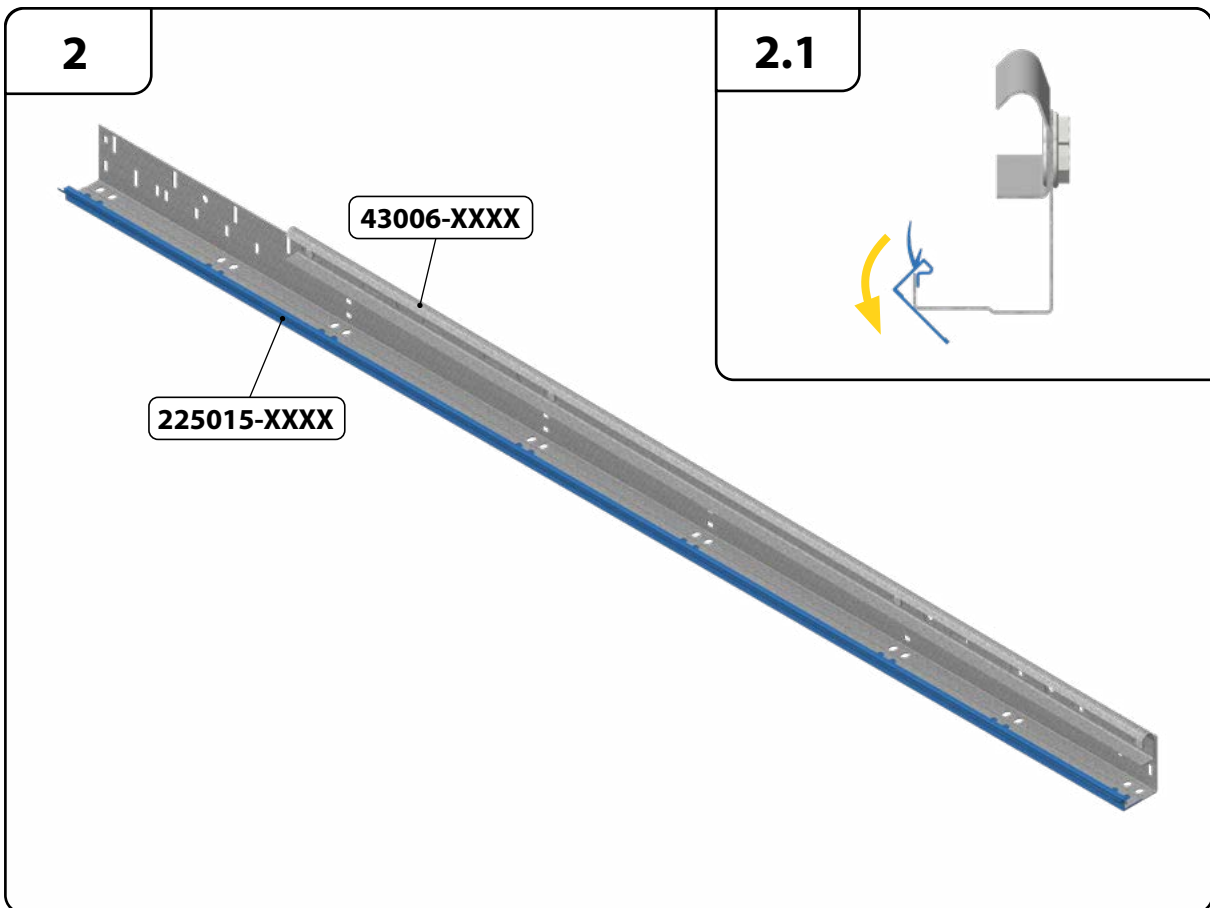
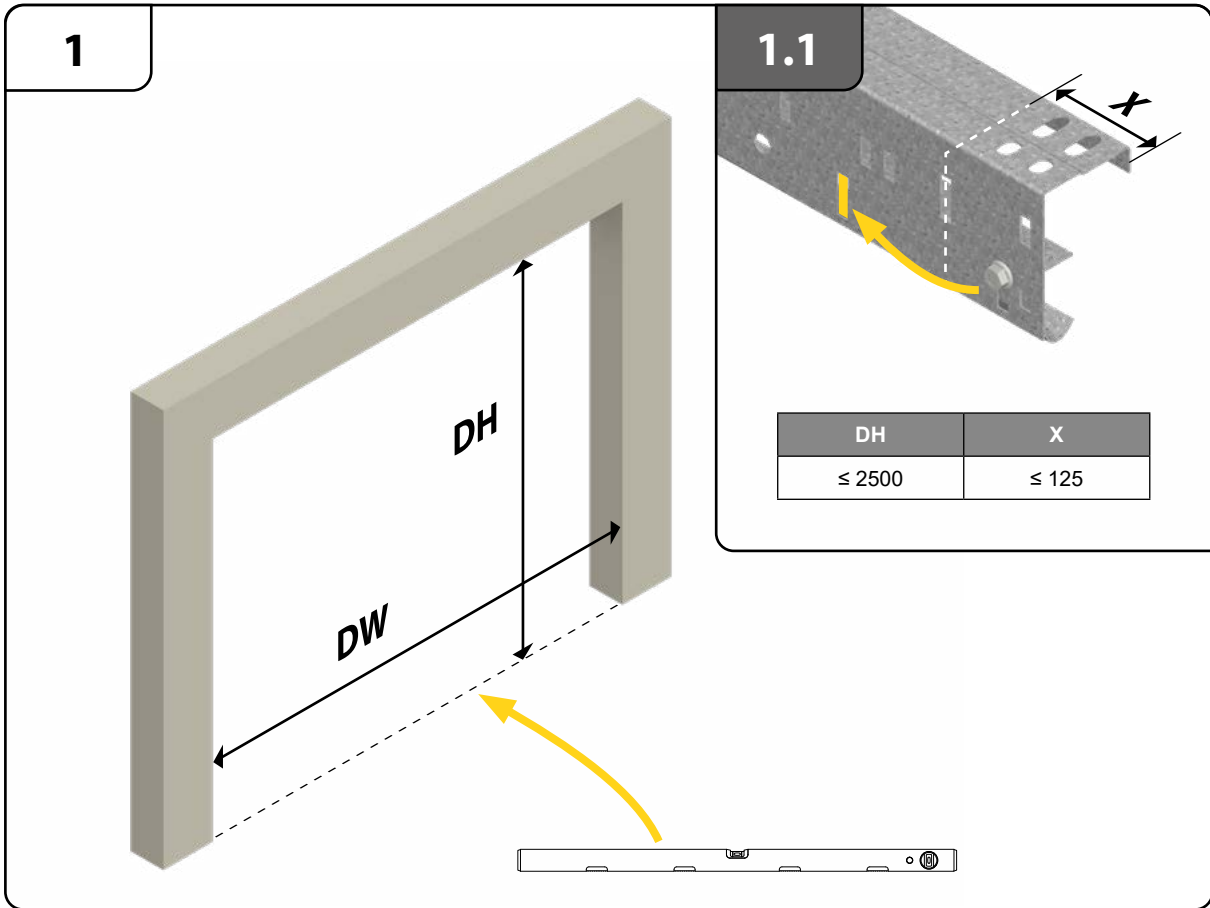

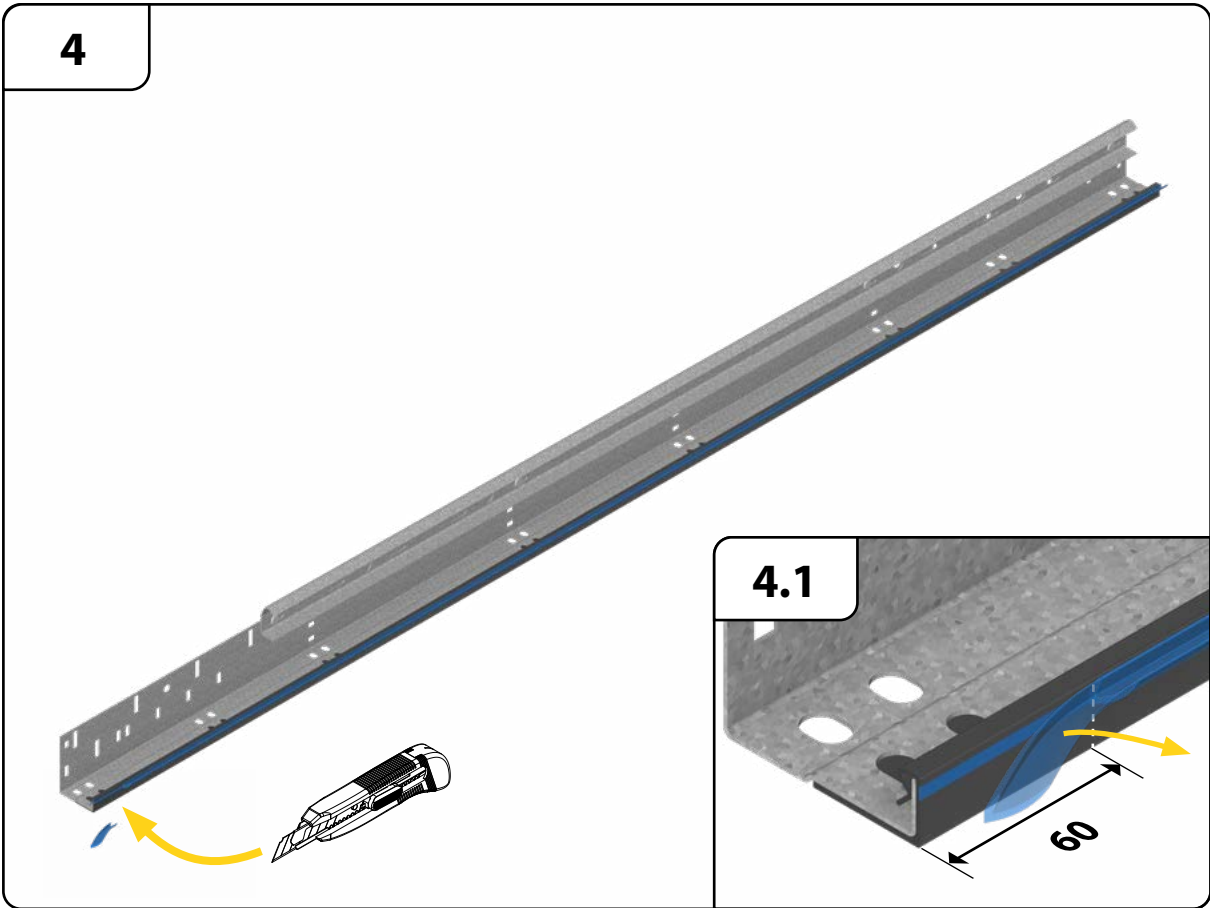
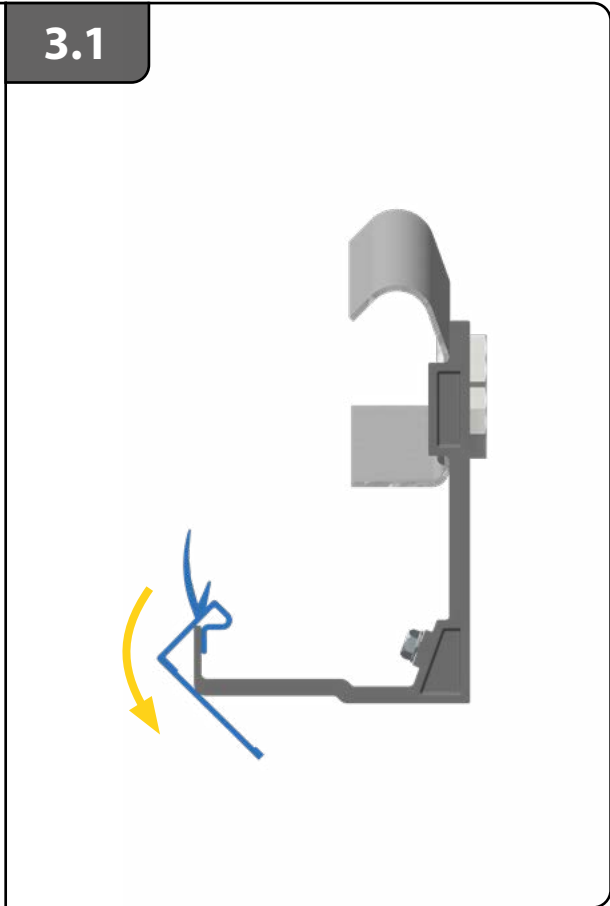
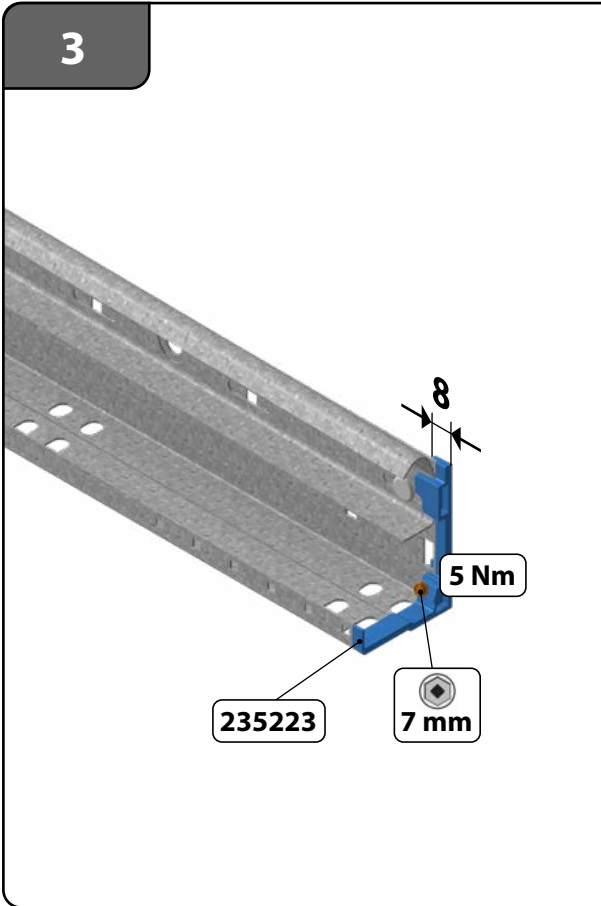

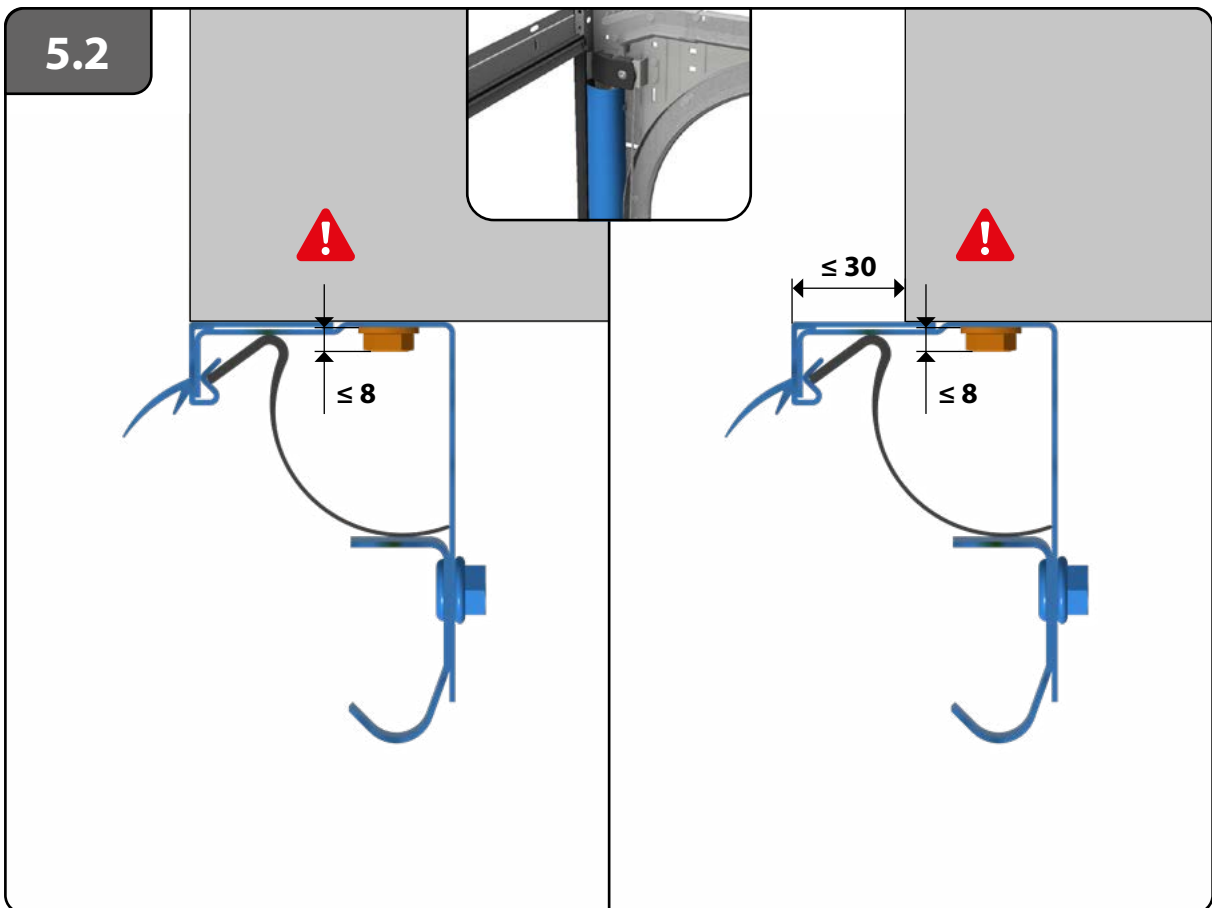
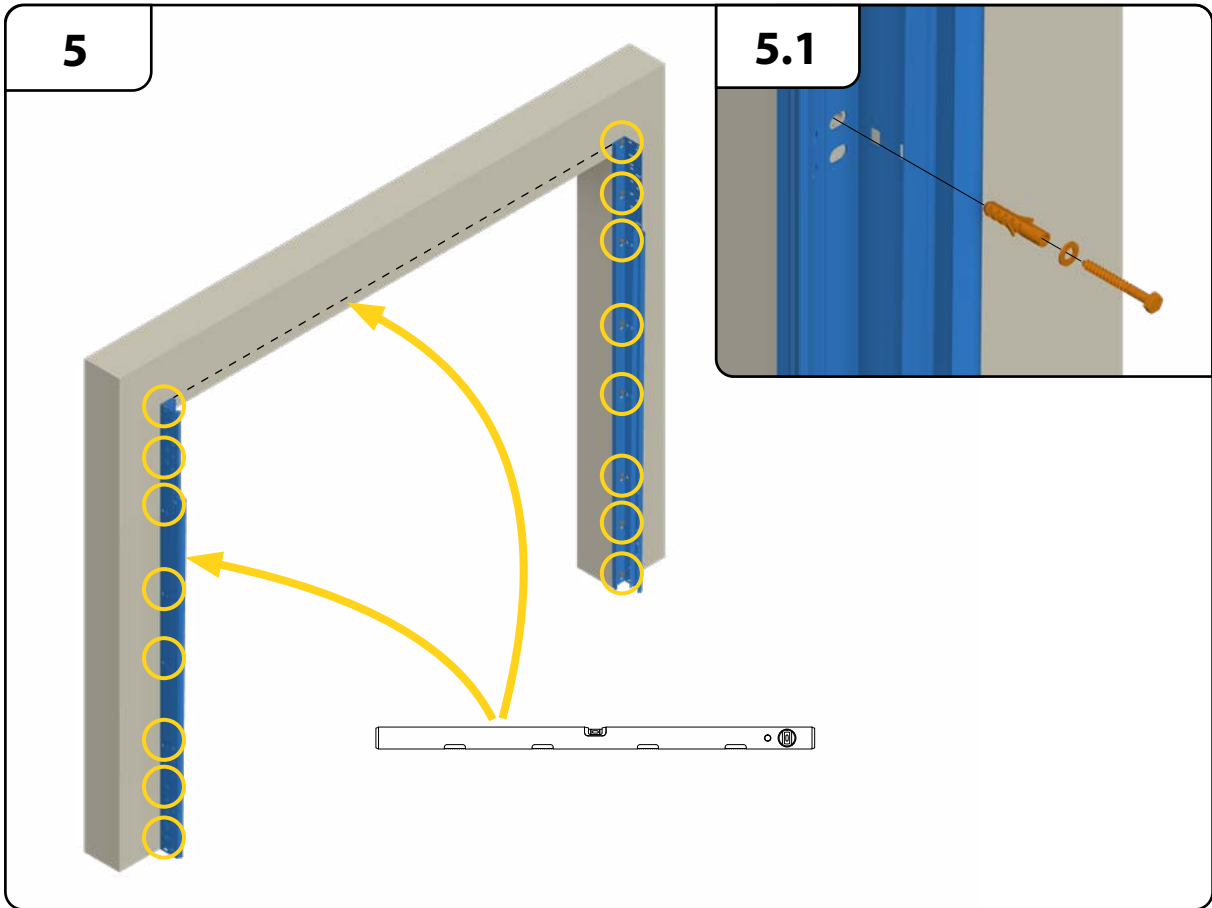

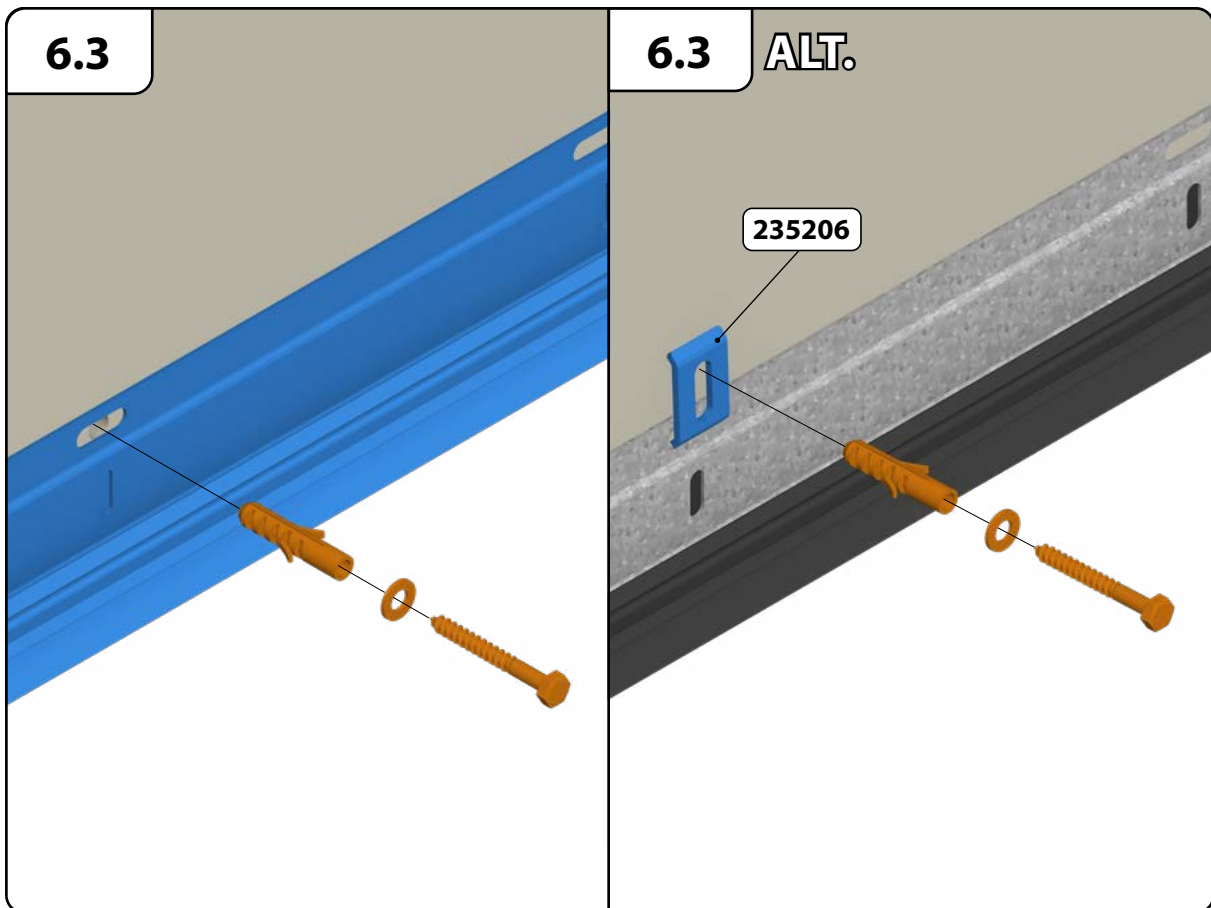
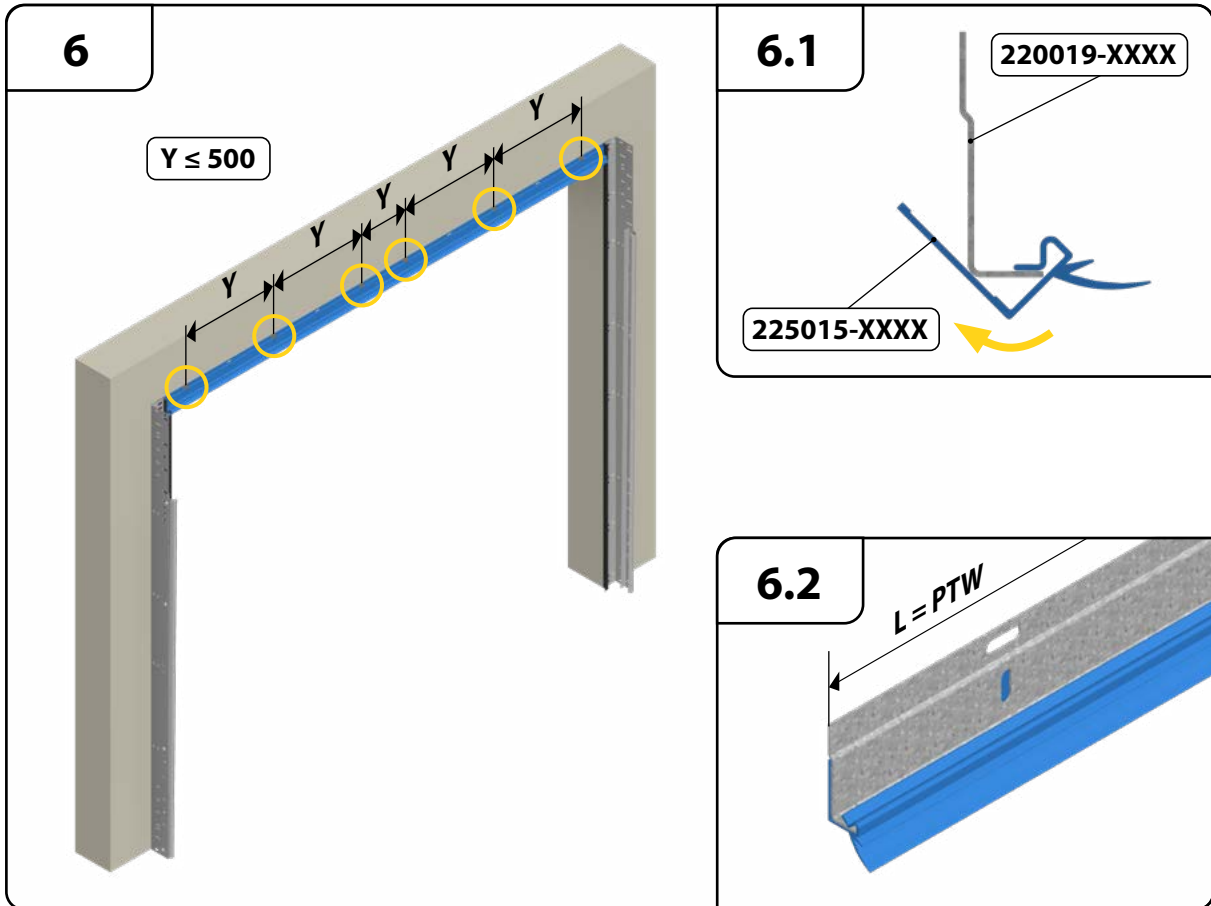

7

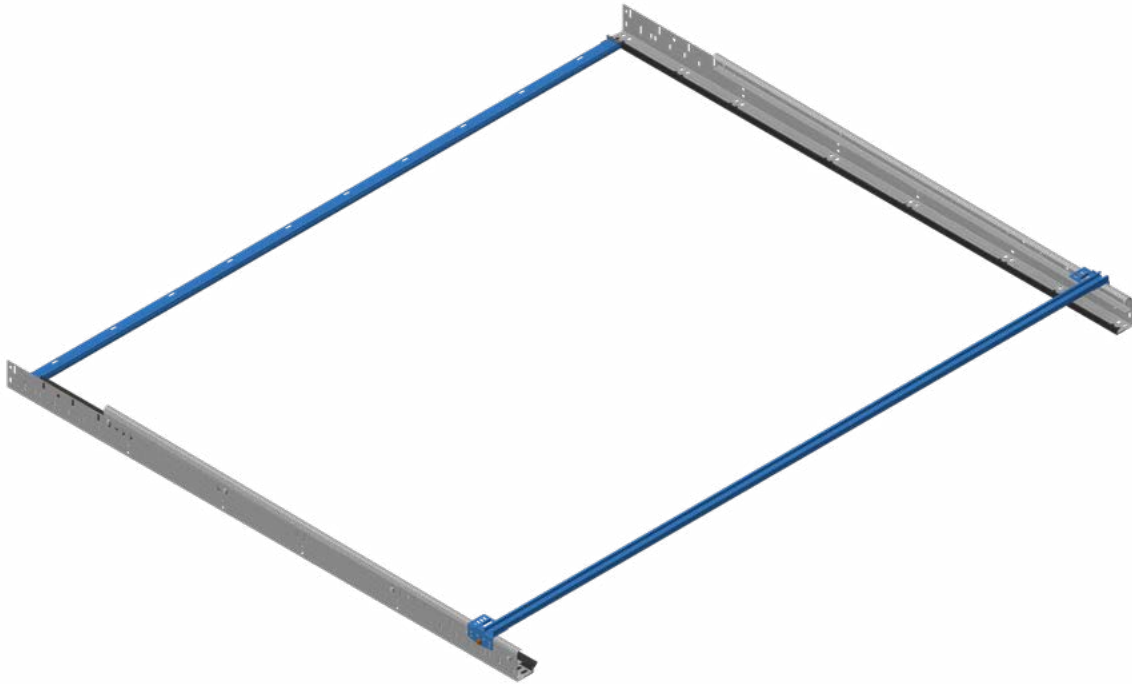

7.1

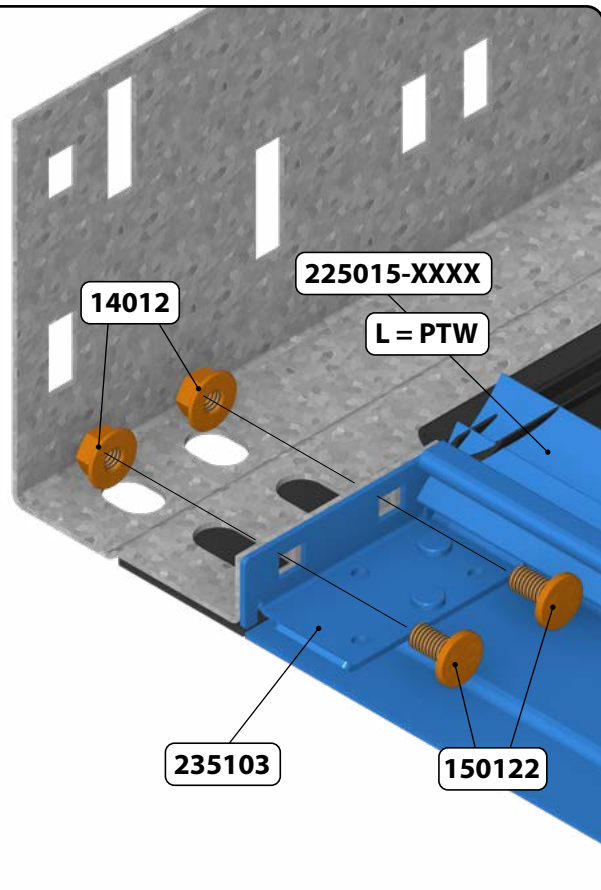
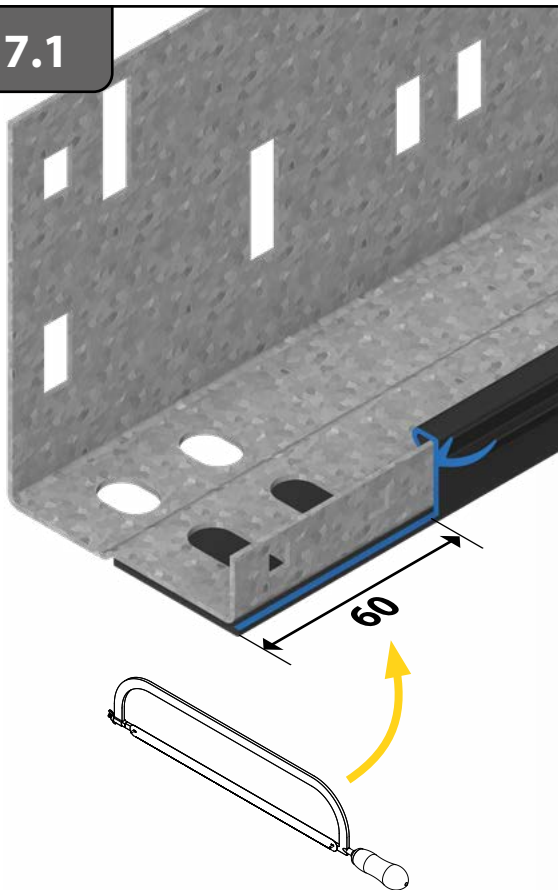

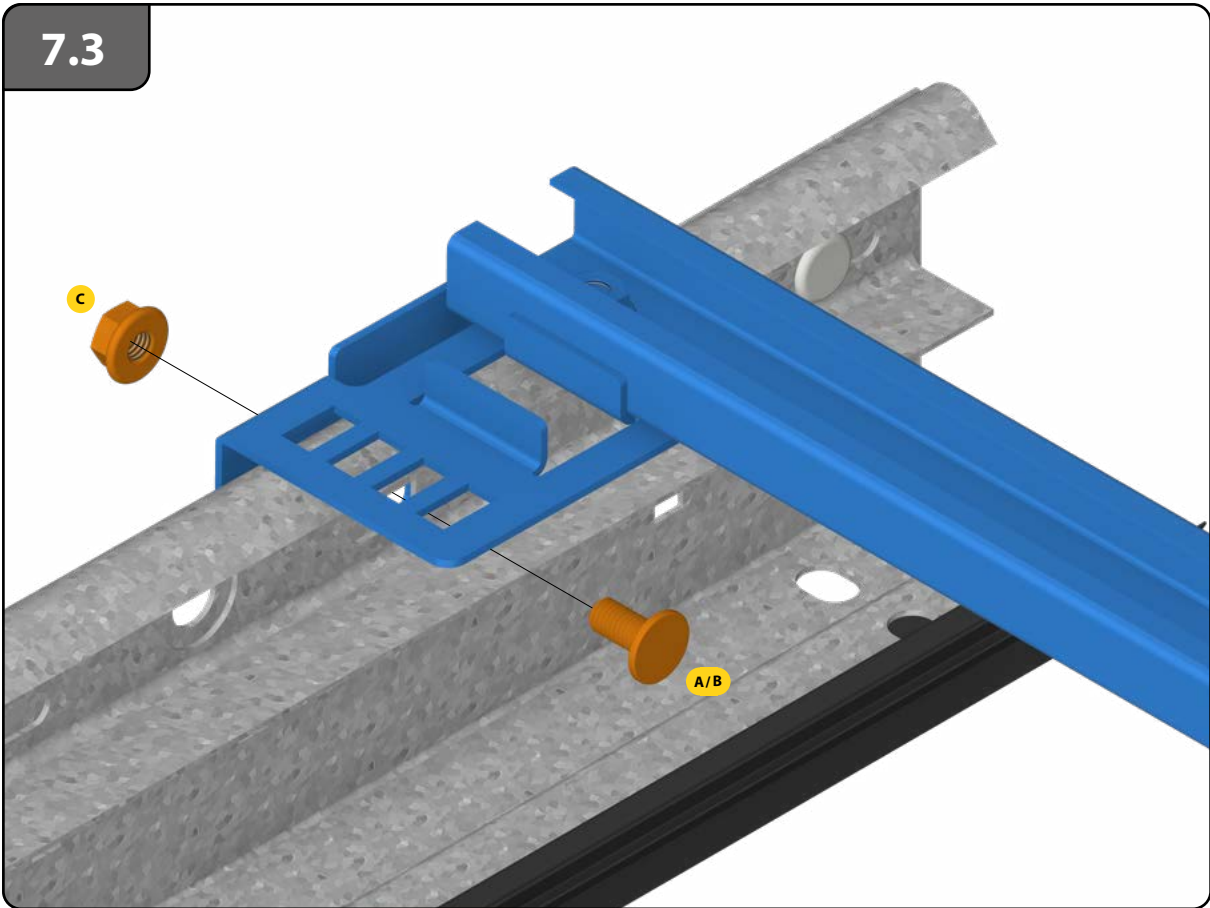
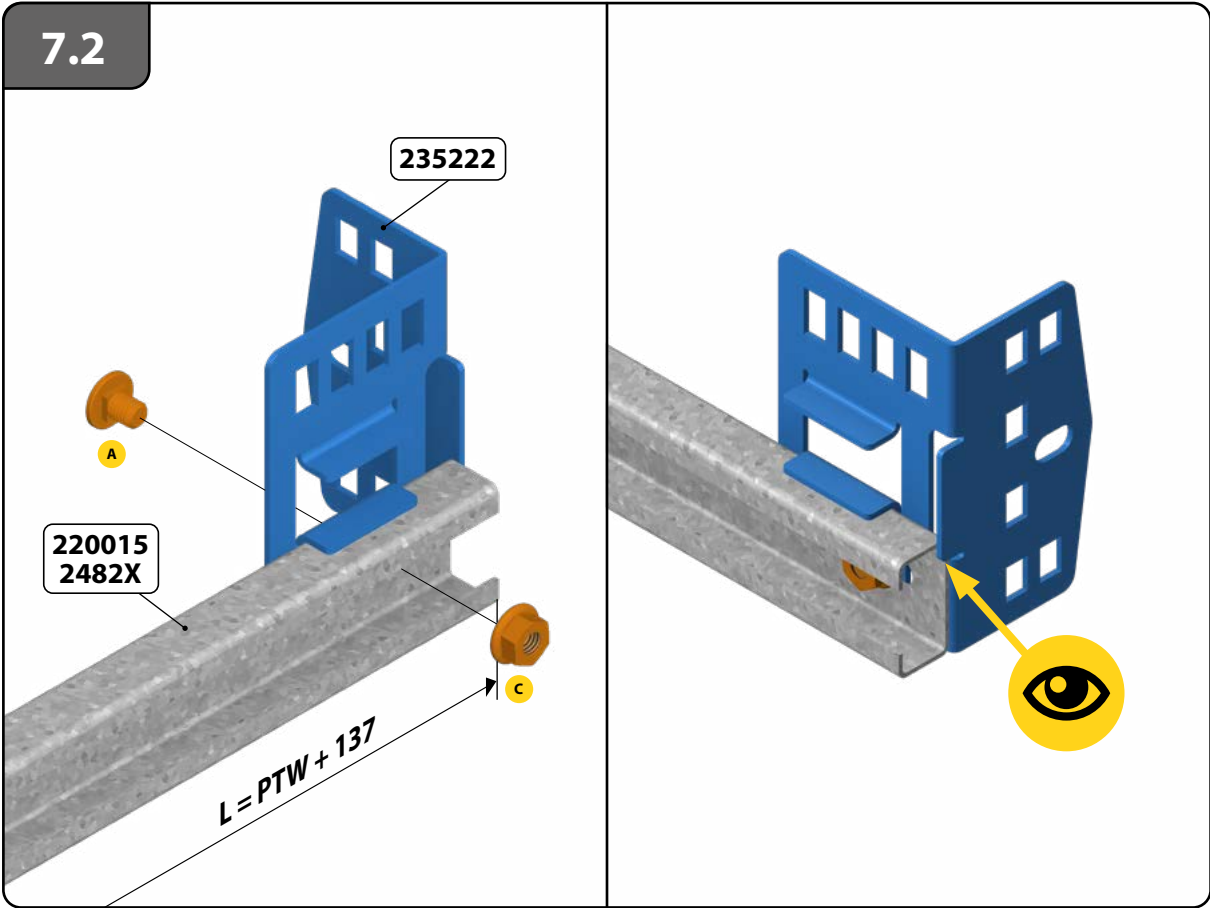

7.4

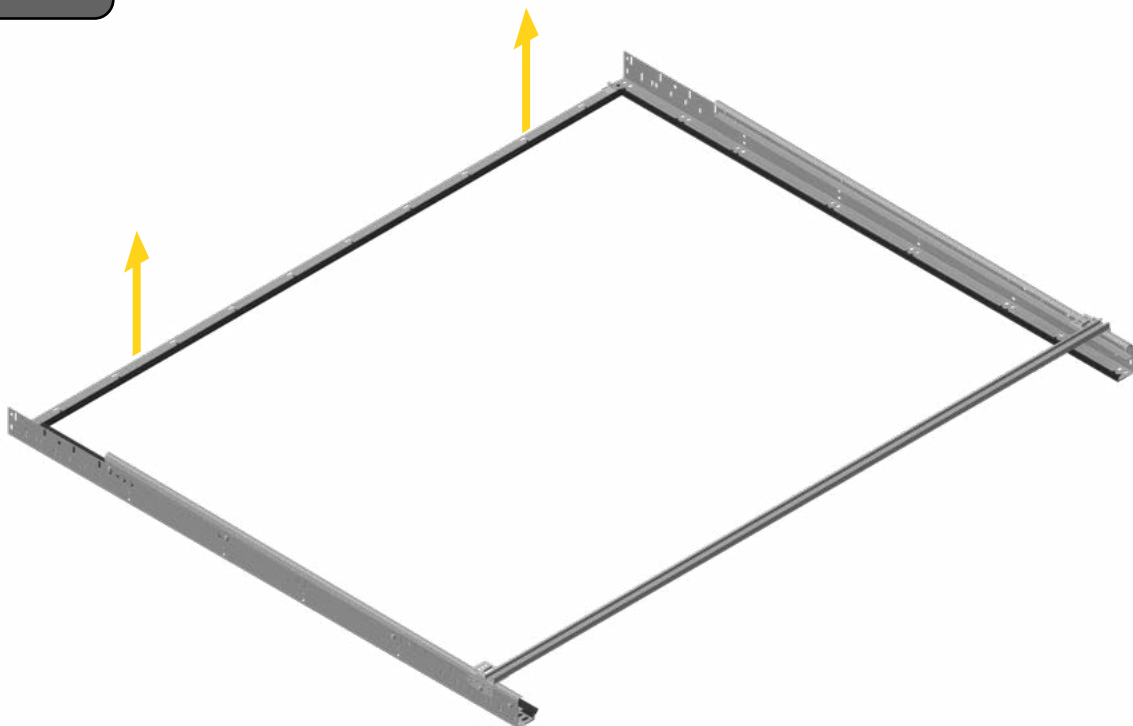

7.5

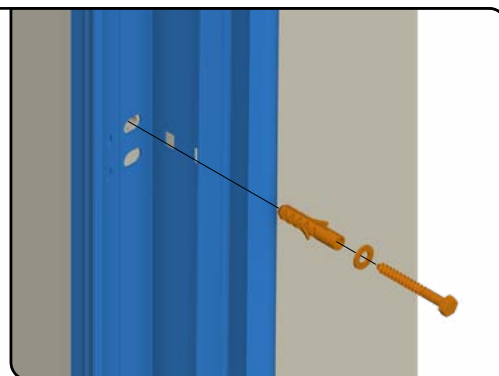
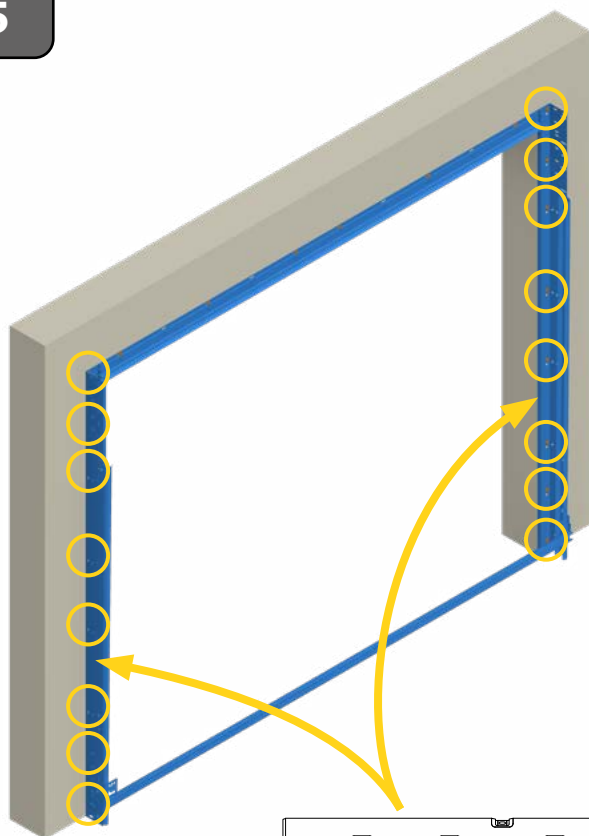

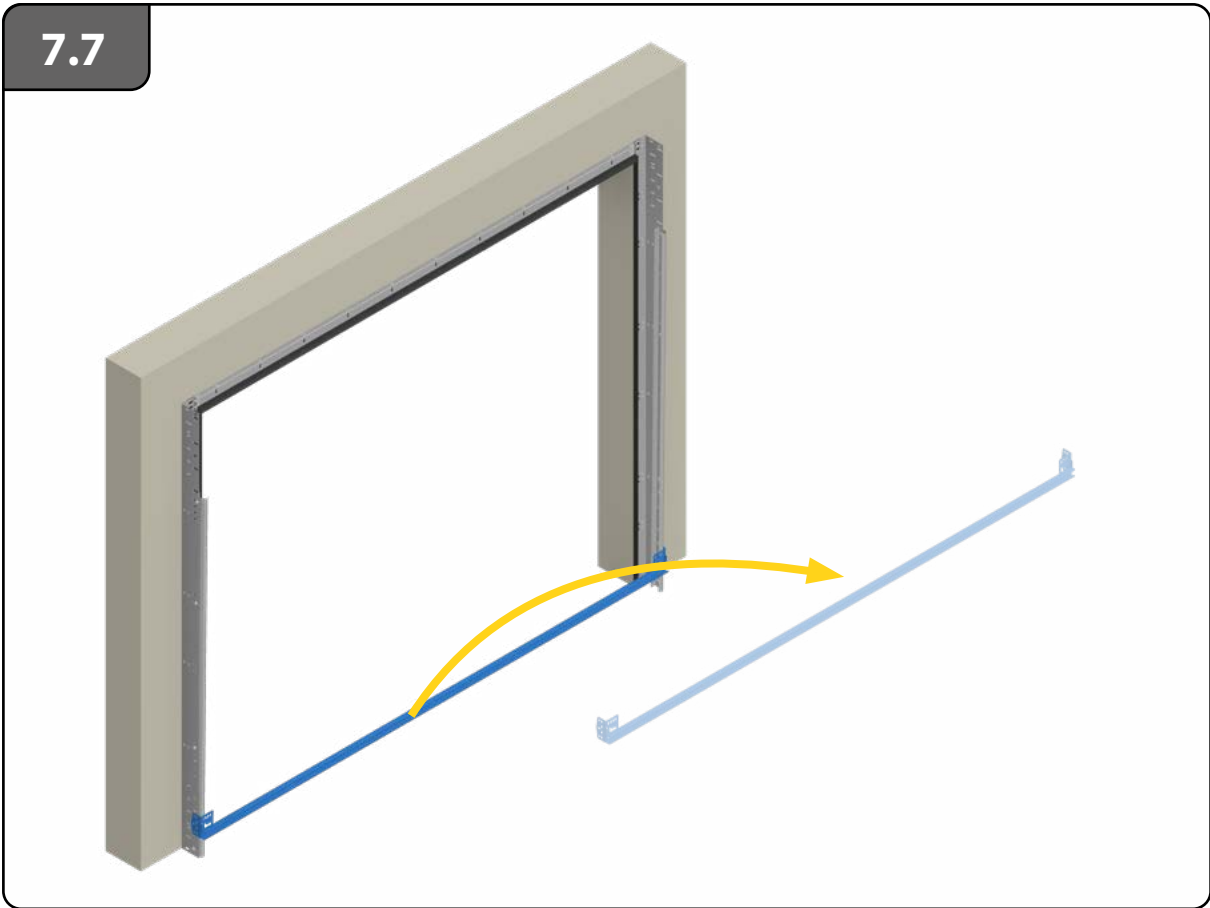
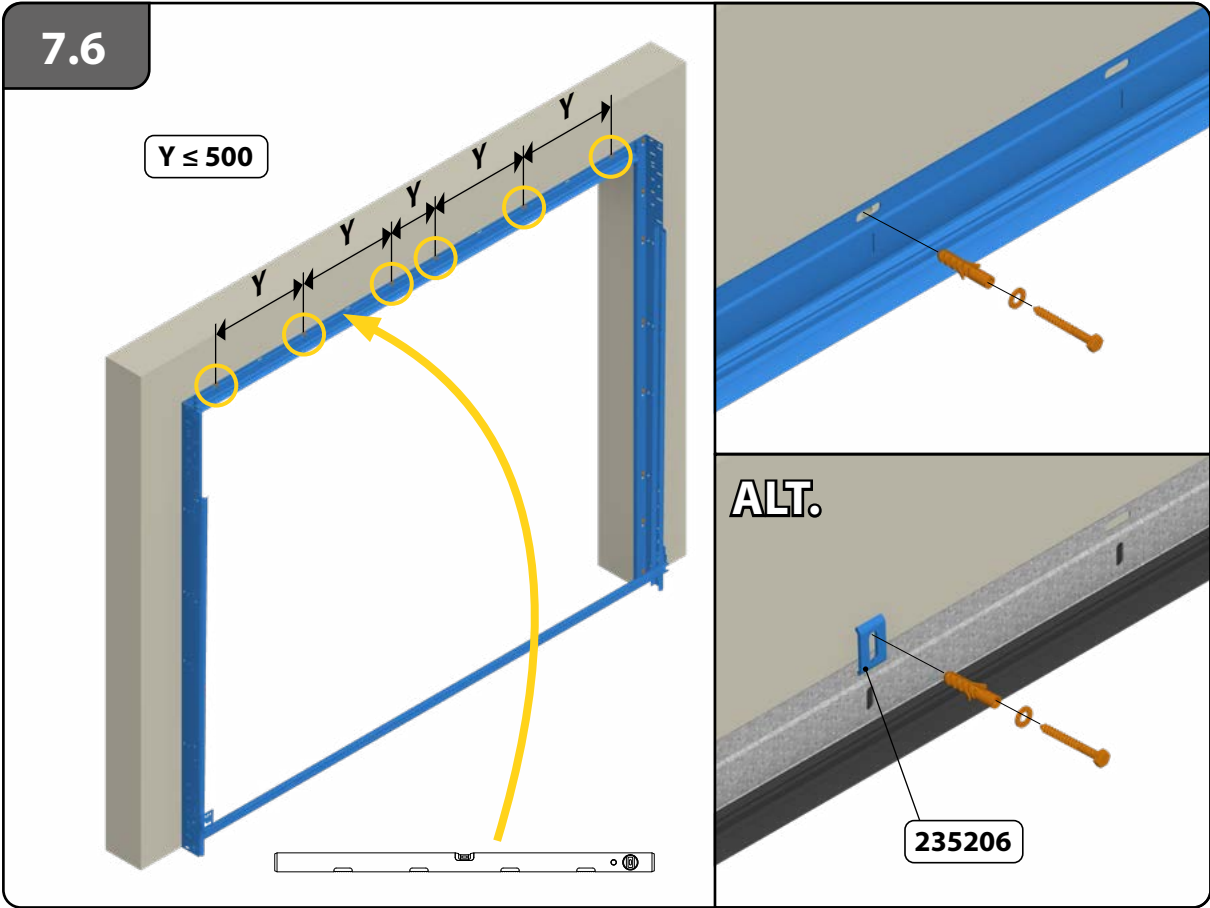

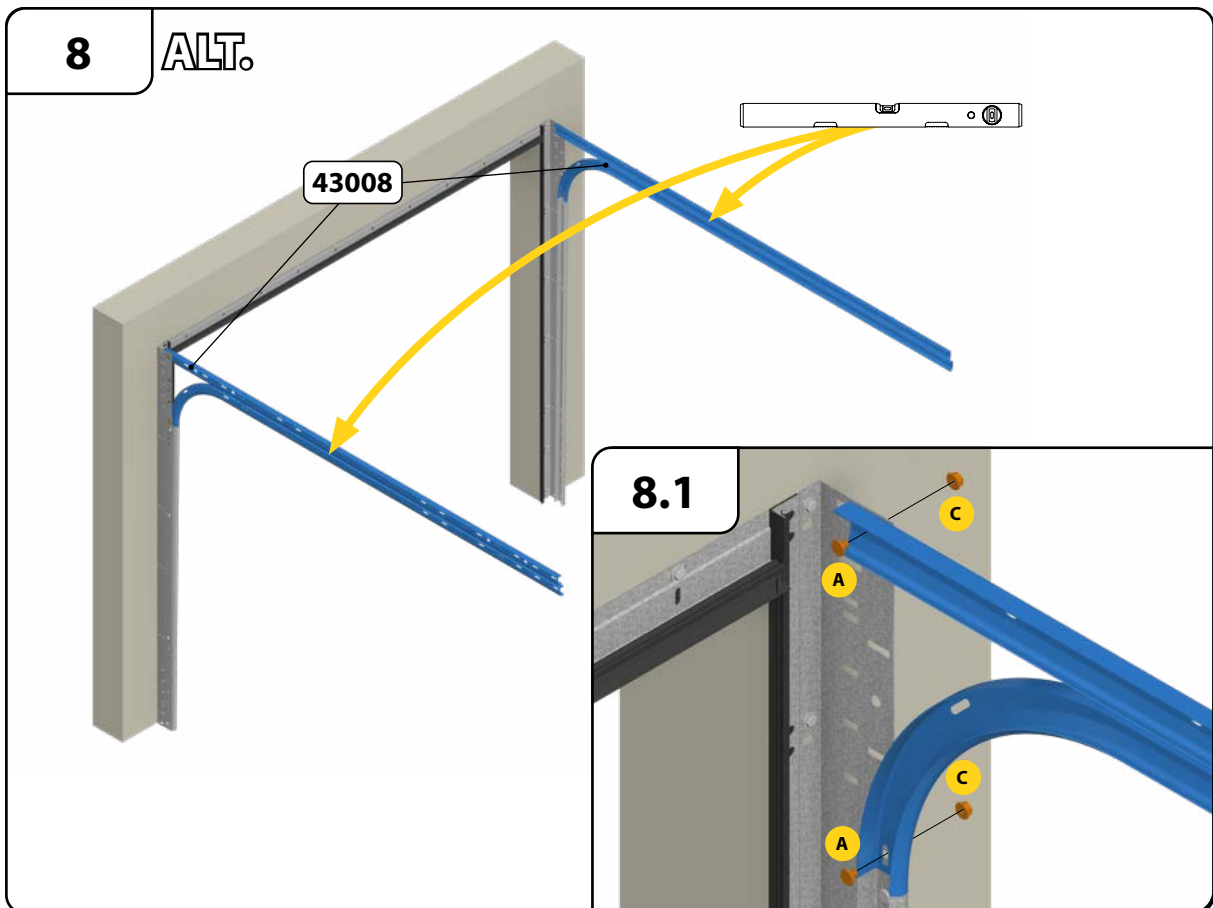
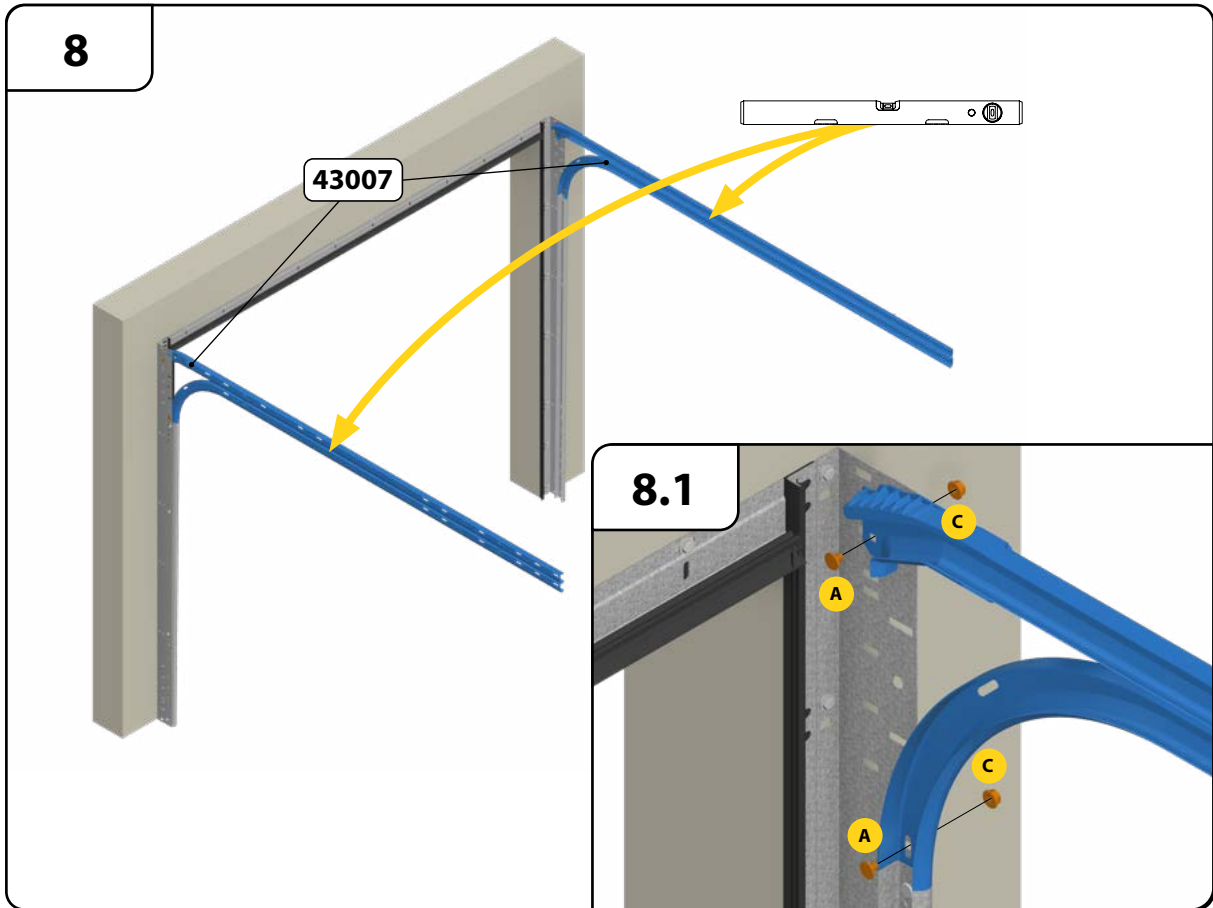

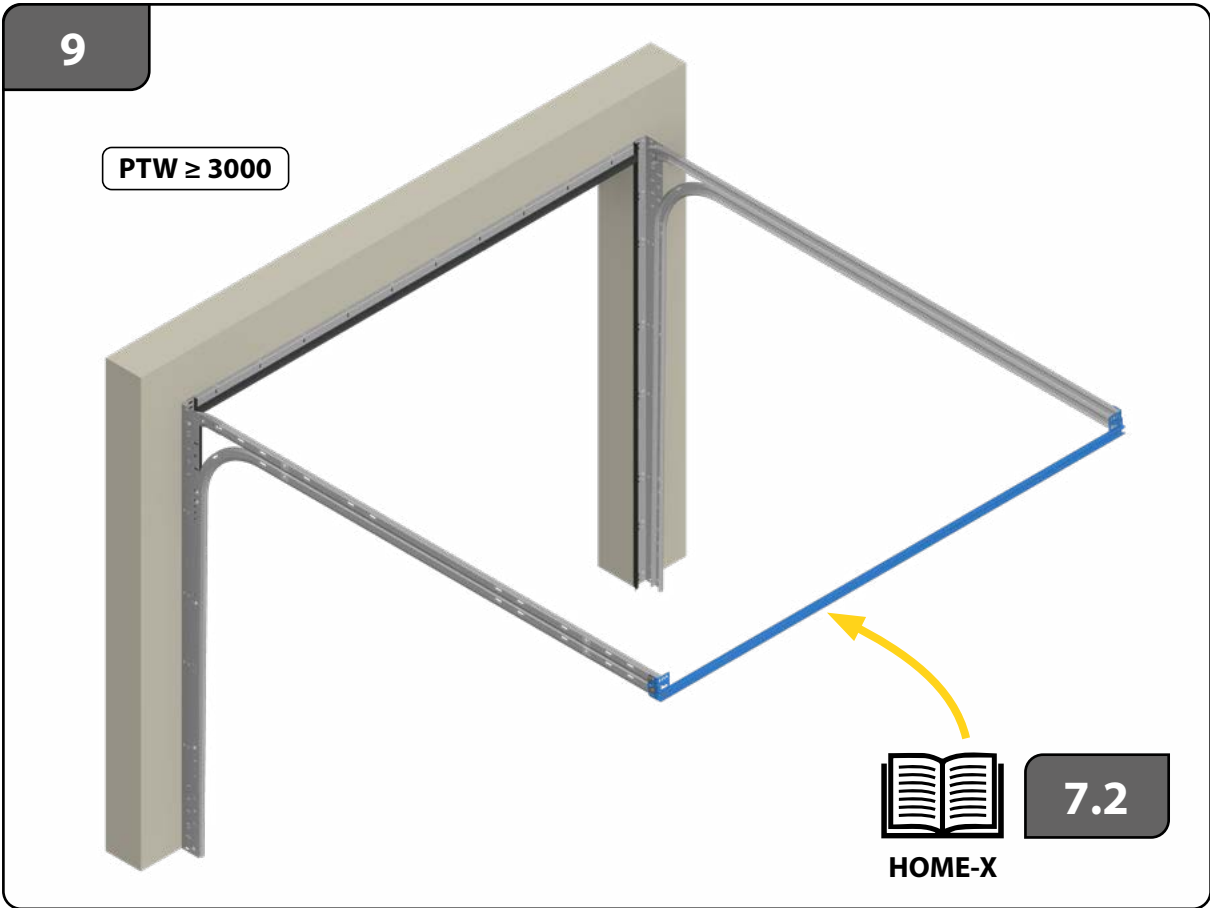
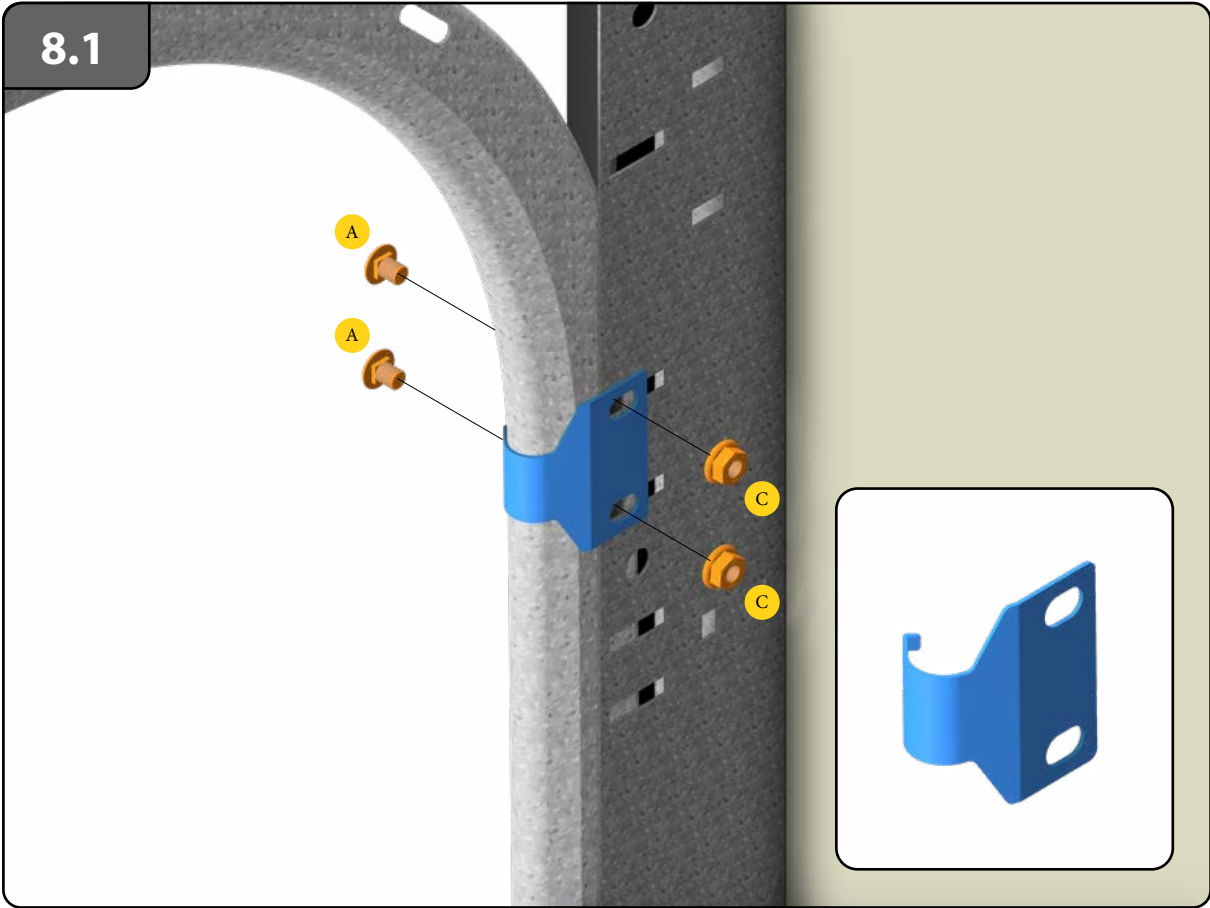

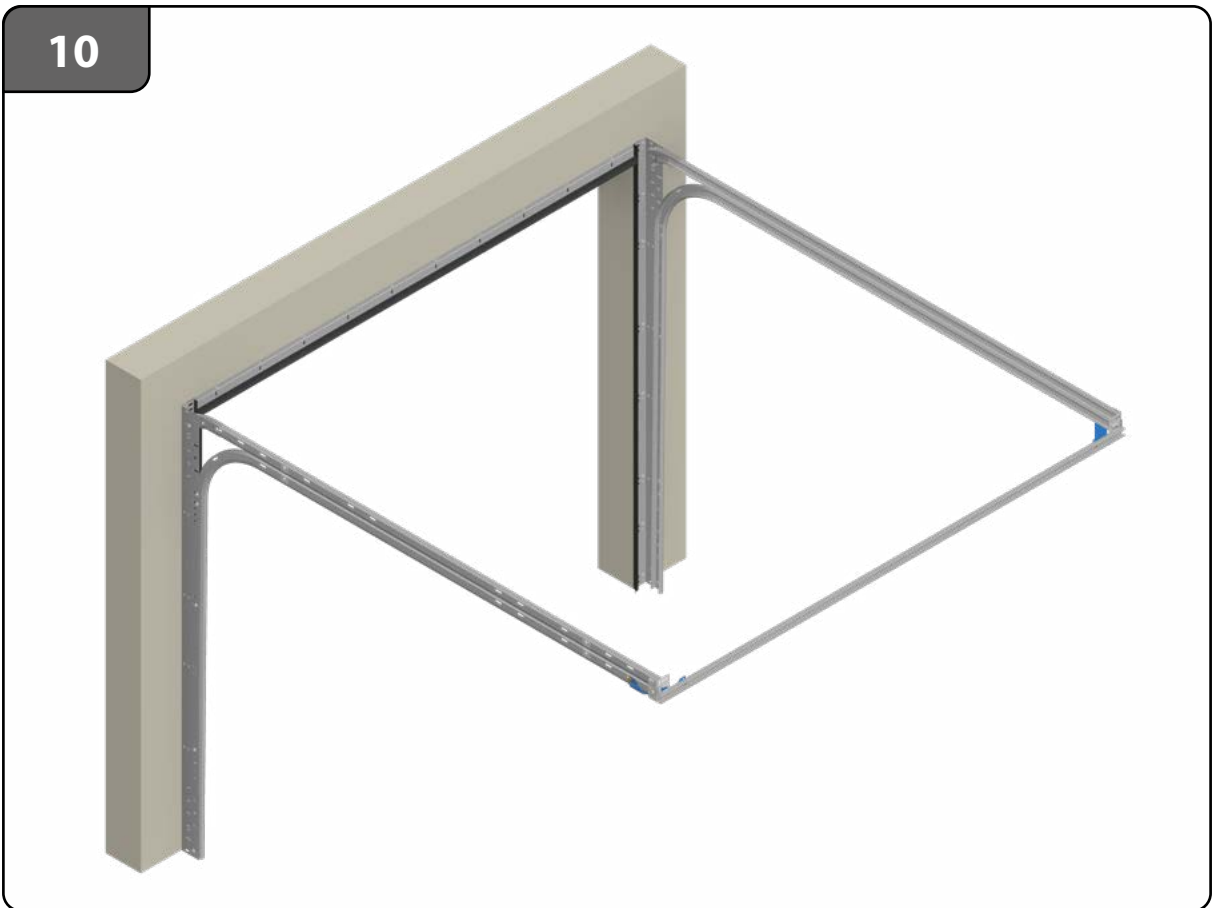
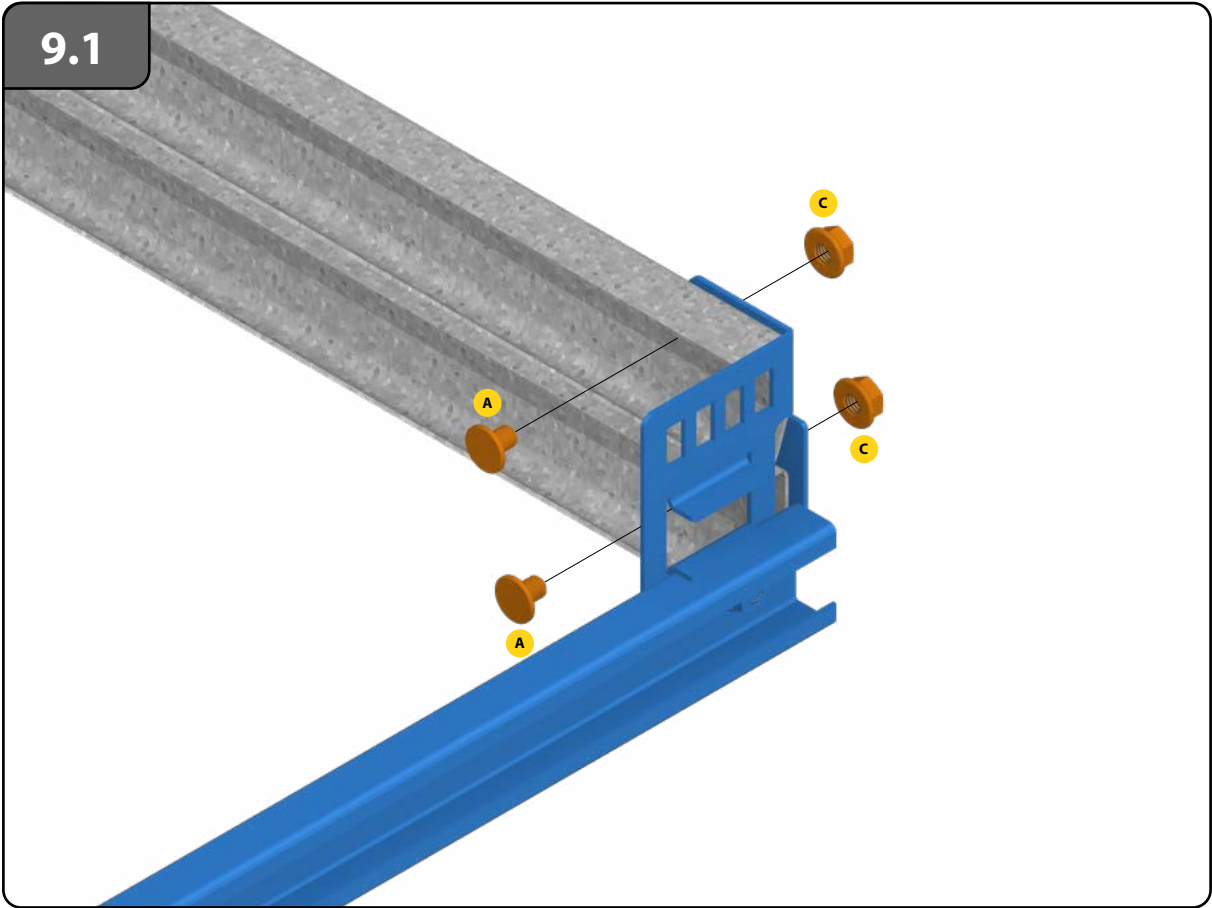

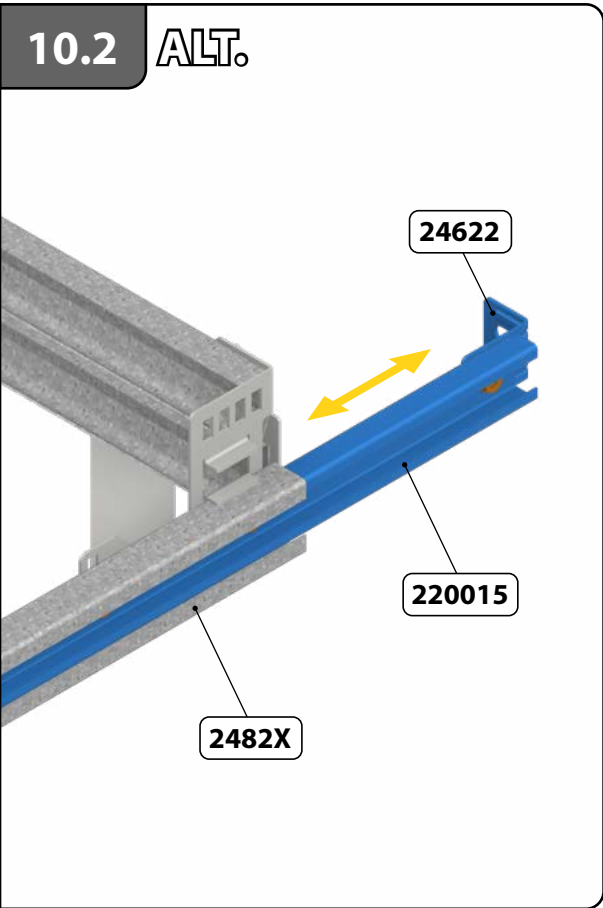
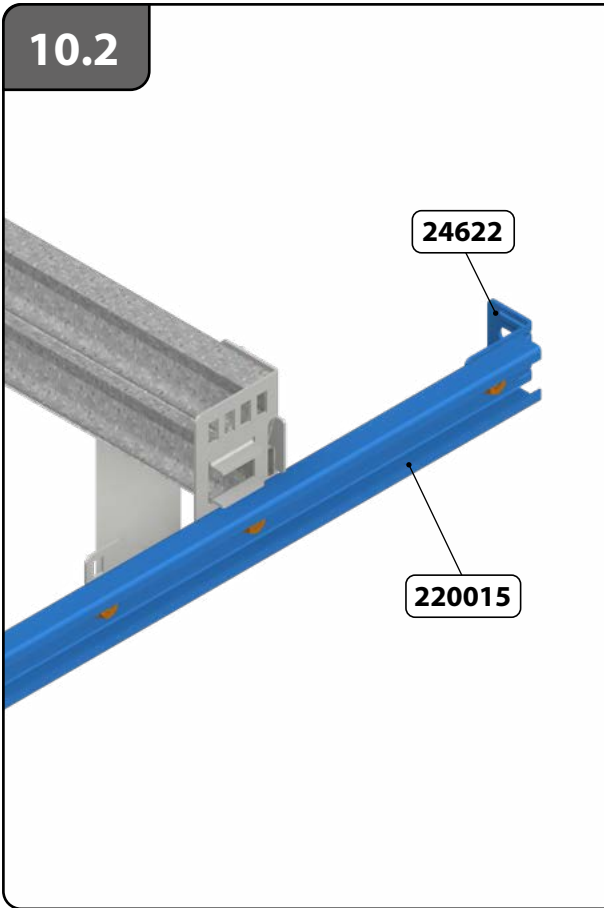
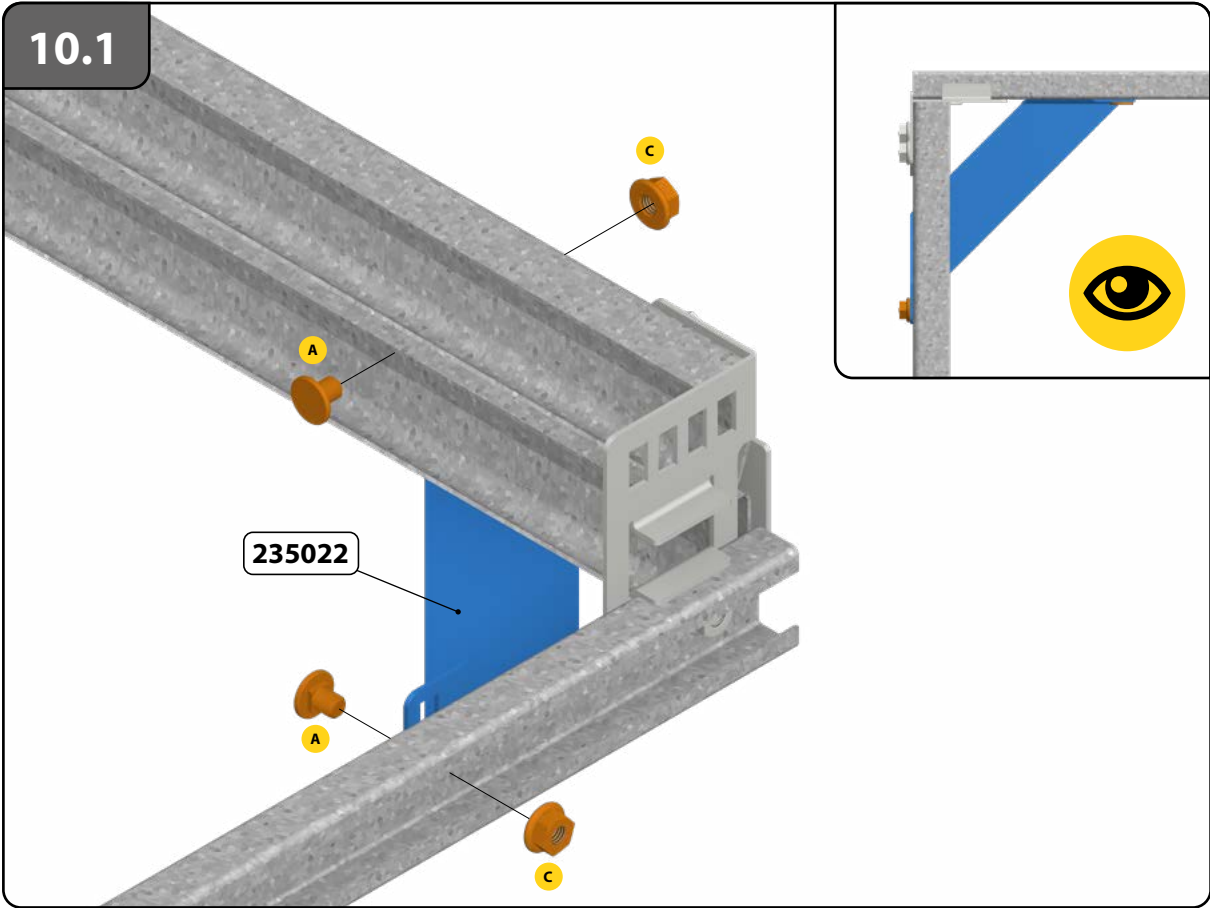

10.2 ALT.

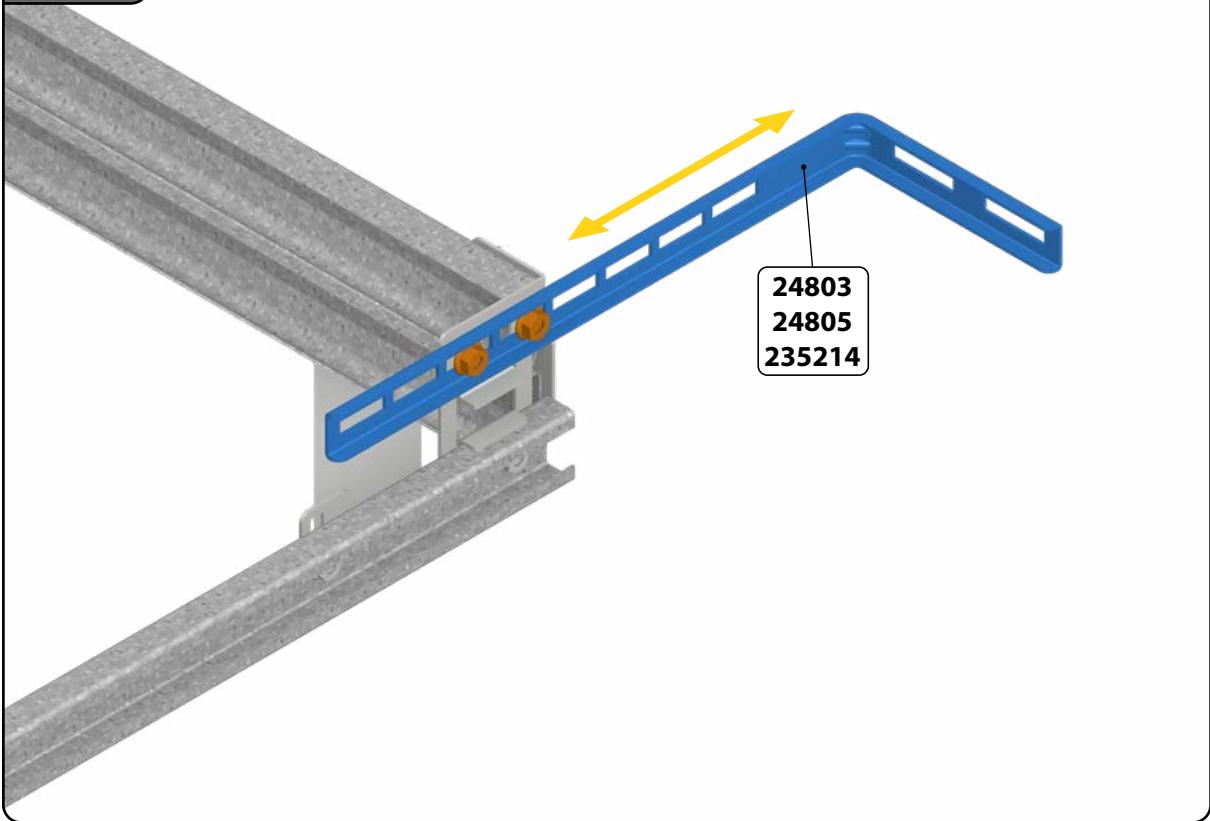

11

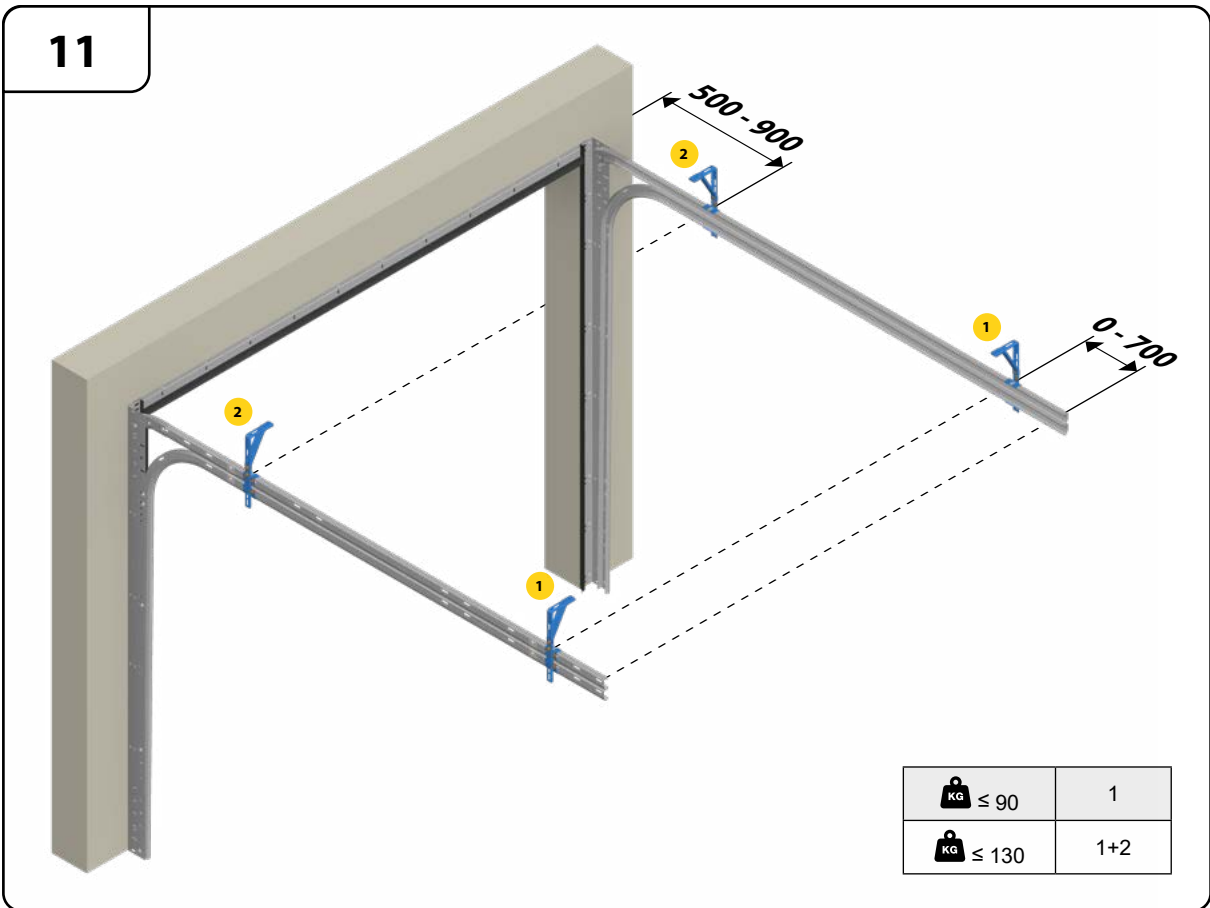

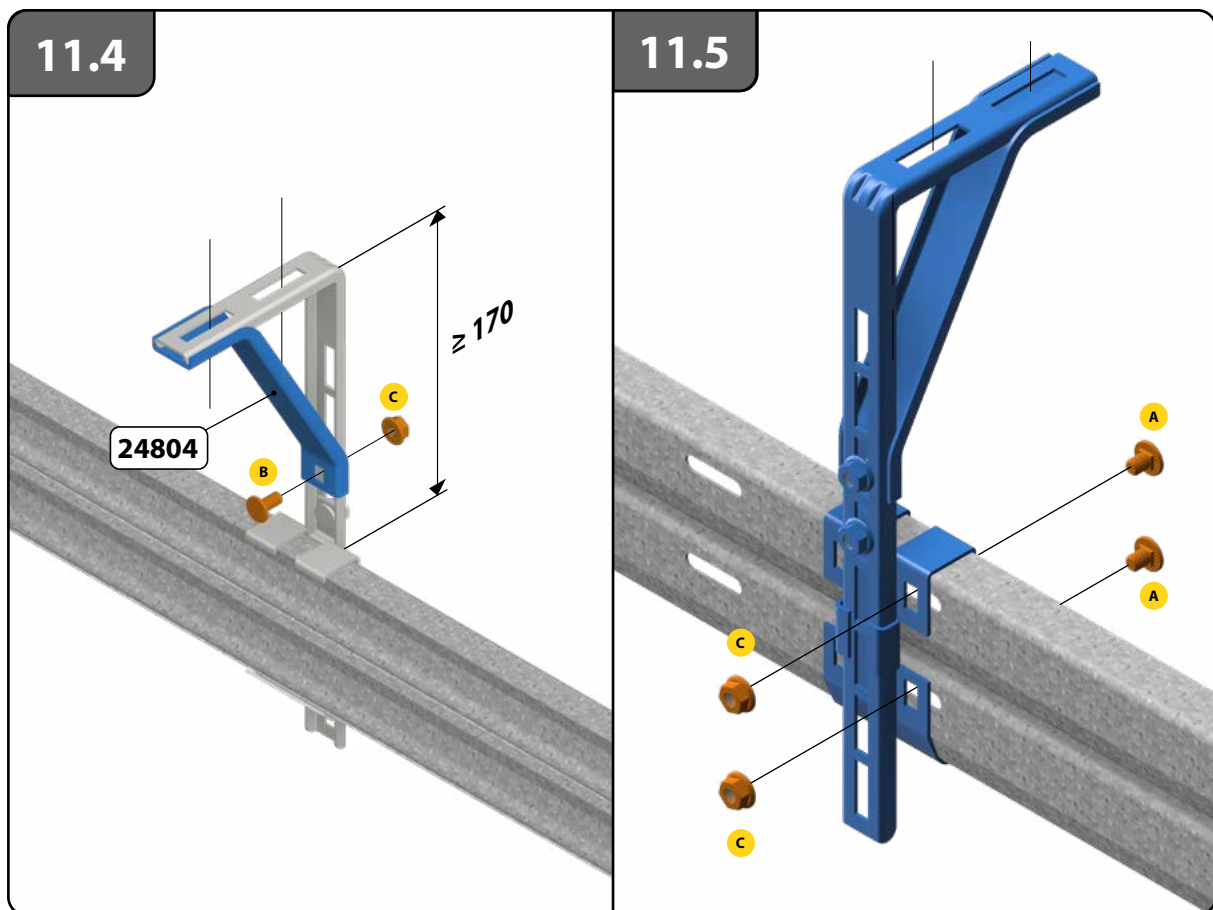
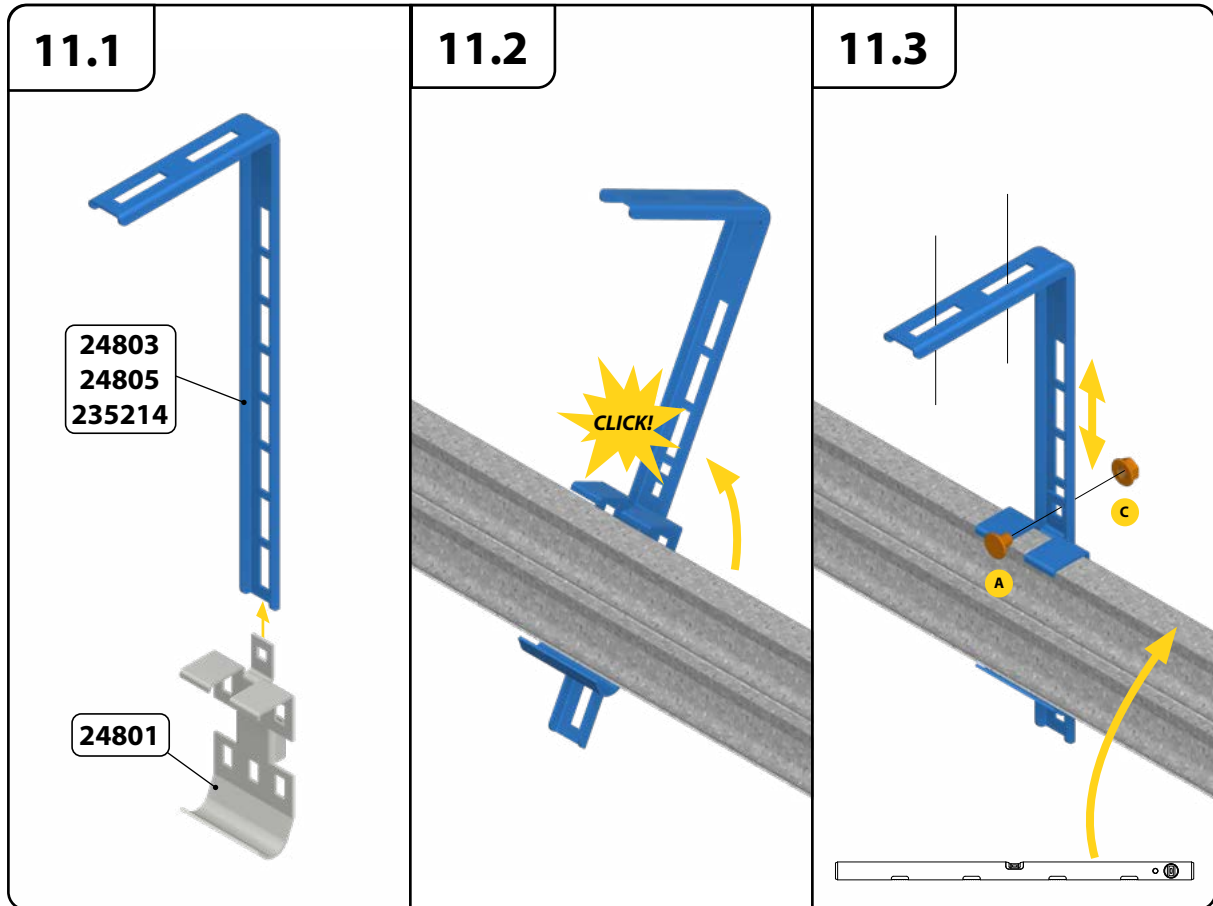

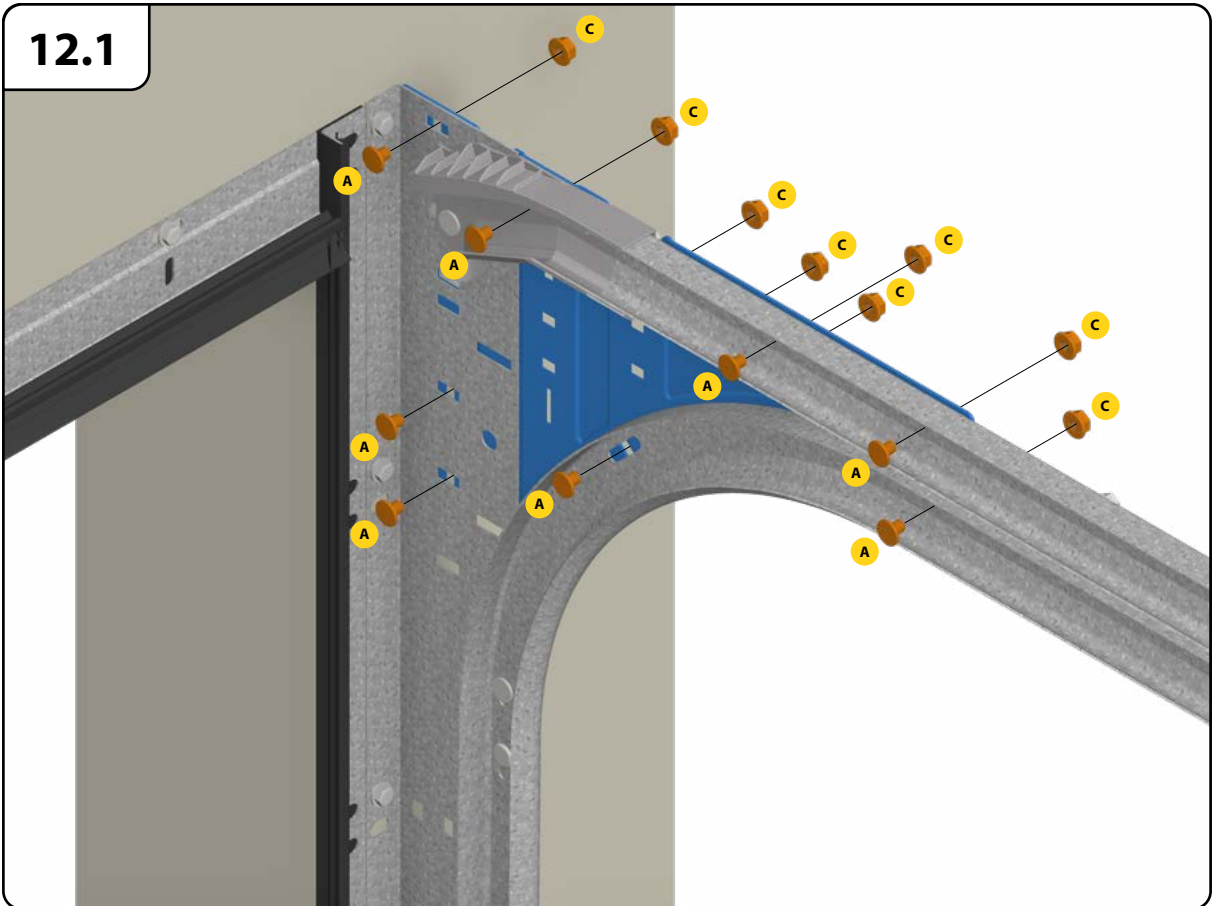
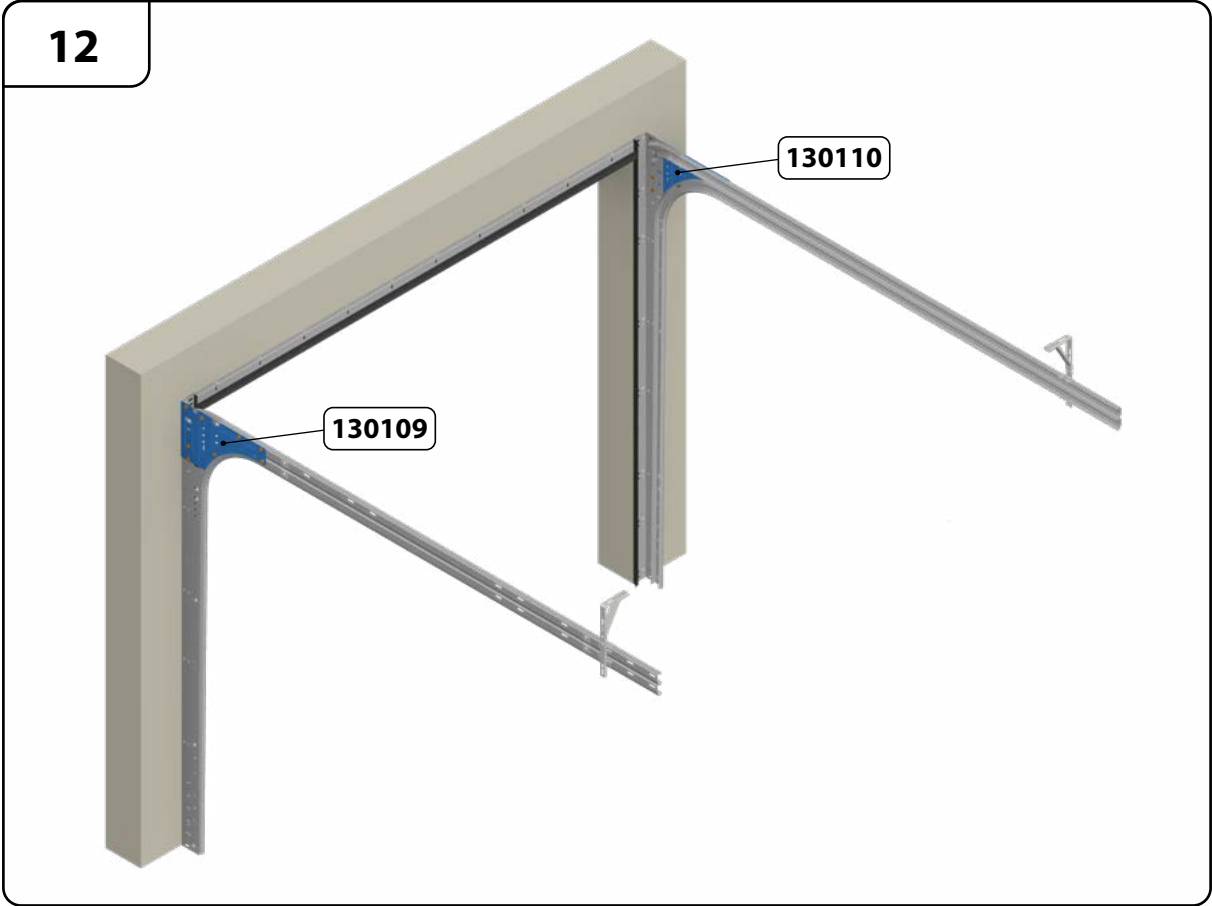

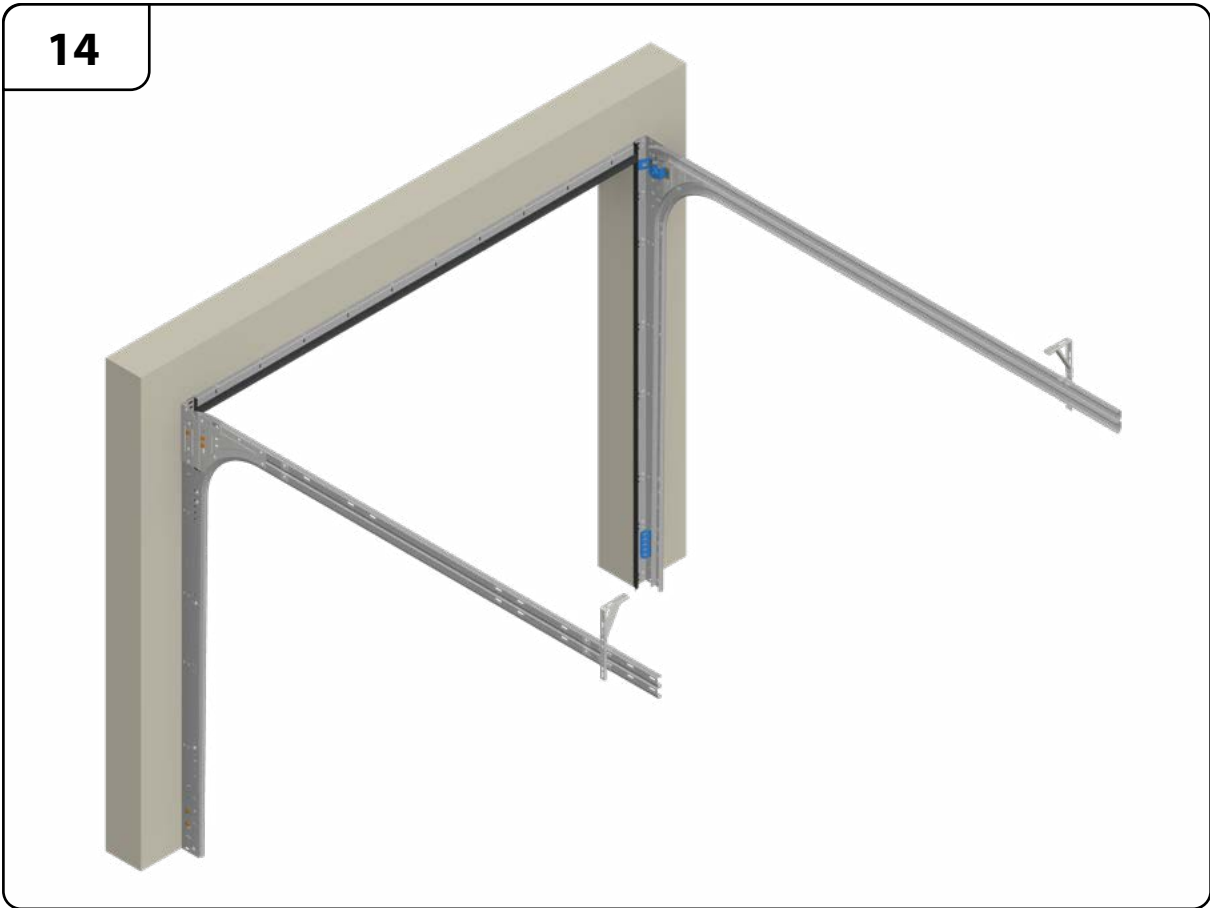
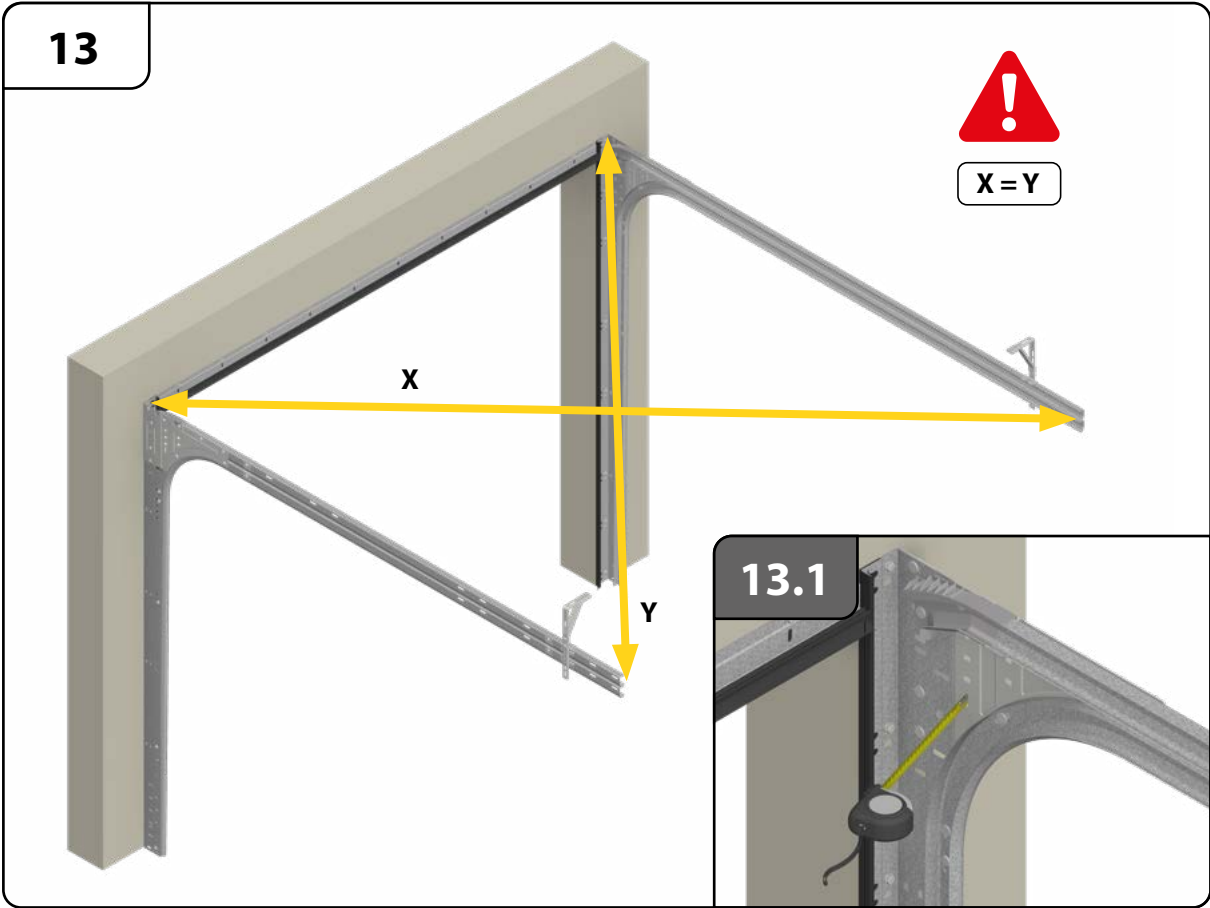

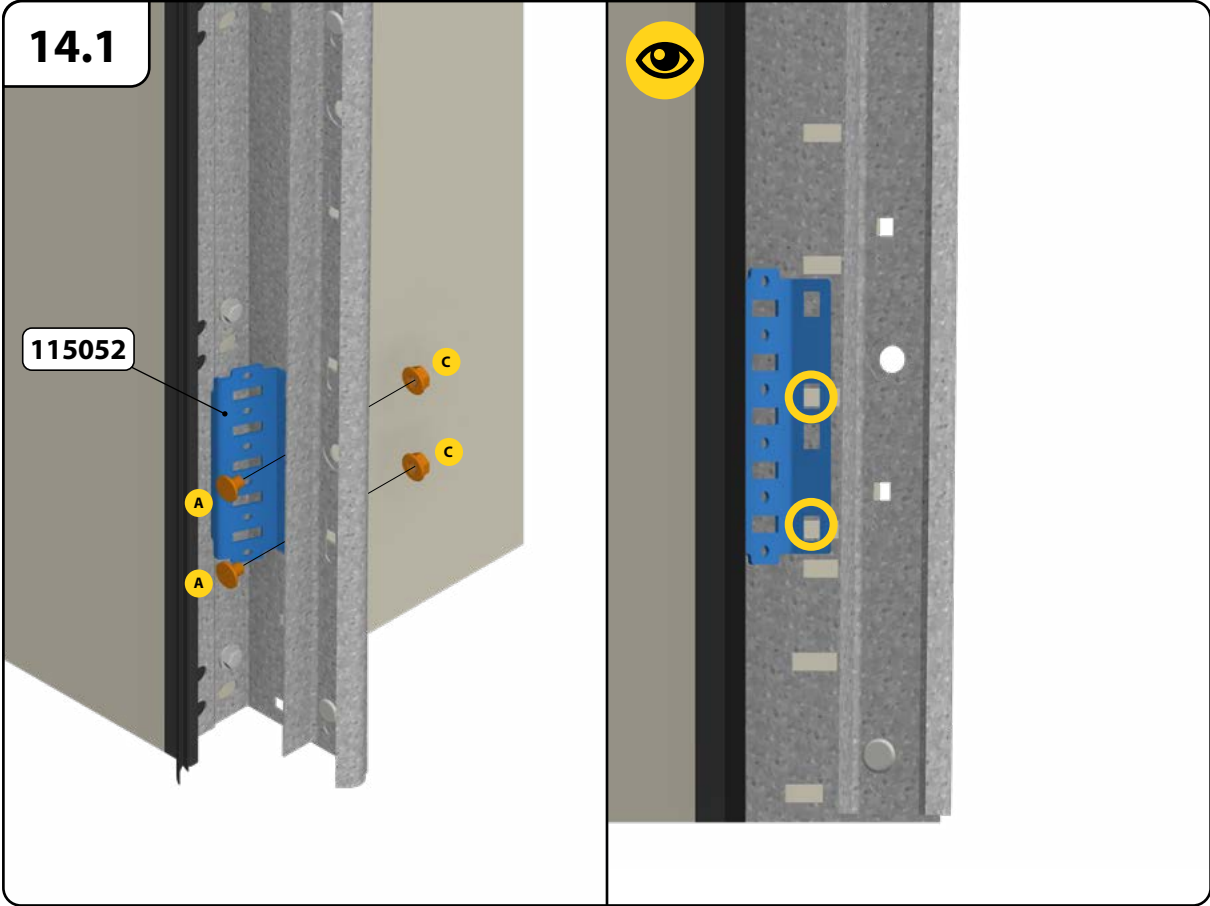

14.2

DH	Position
1751-1875	A
1876-2000	
2001-2125	
2126-2250	
2251-2375	
2376-2500	
2501-2625	B
2626-2750	A
2751-2875	B
2876-3000	A

A
B

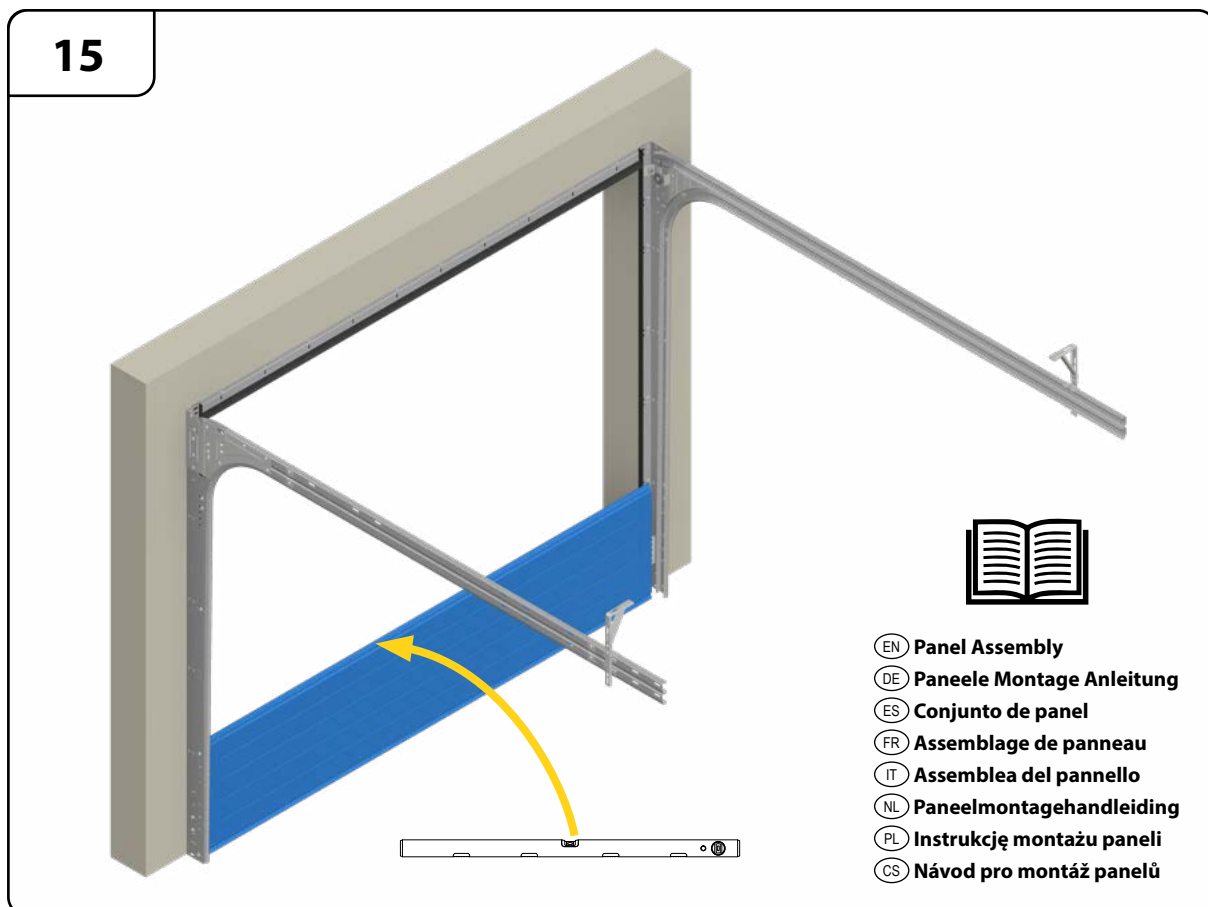
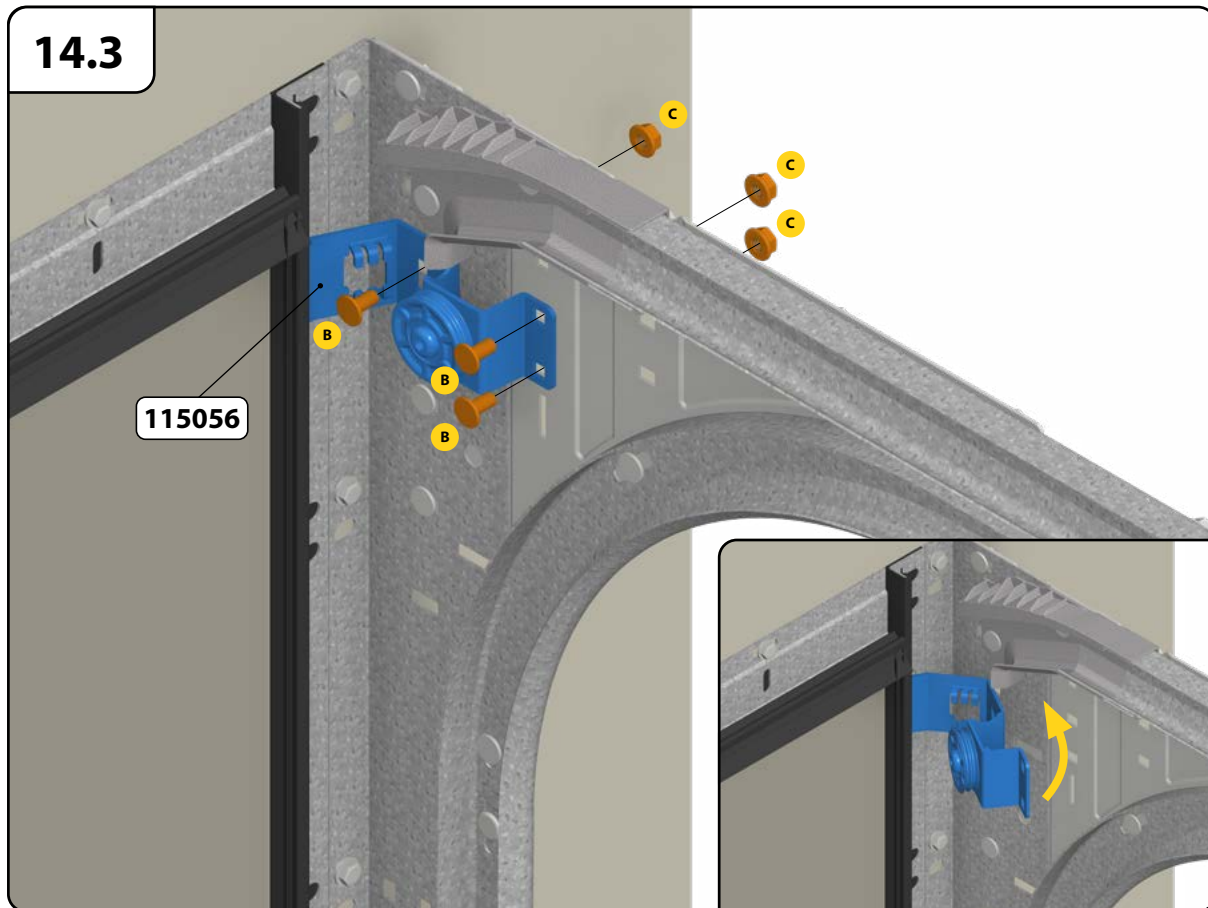

15.1

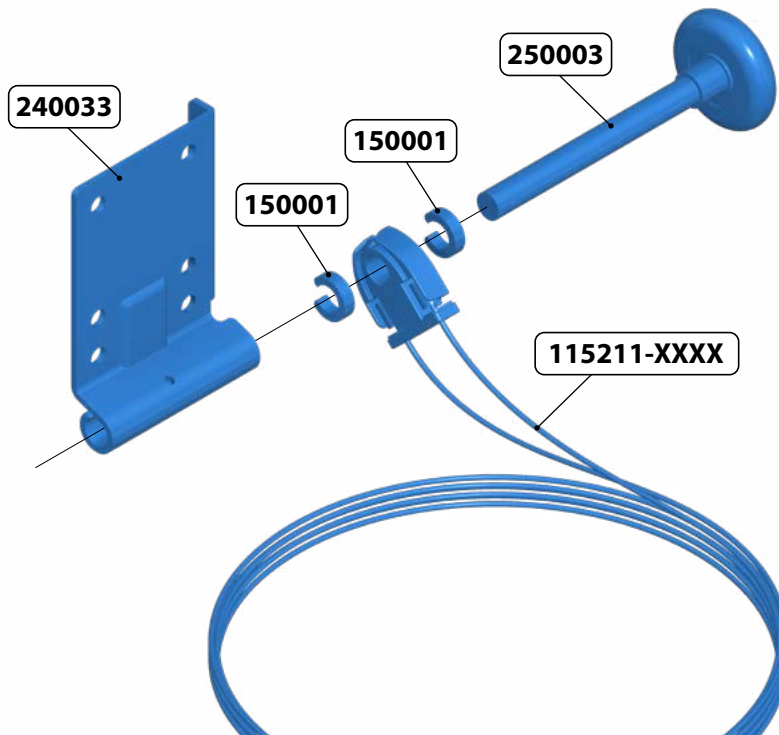

15.2

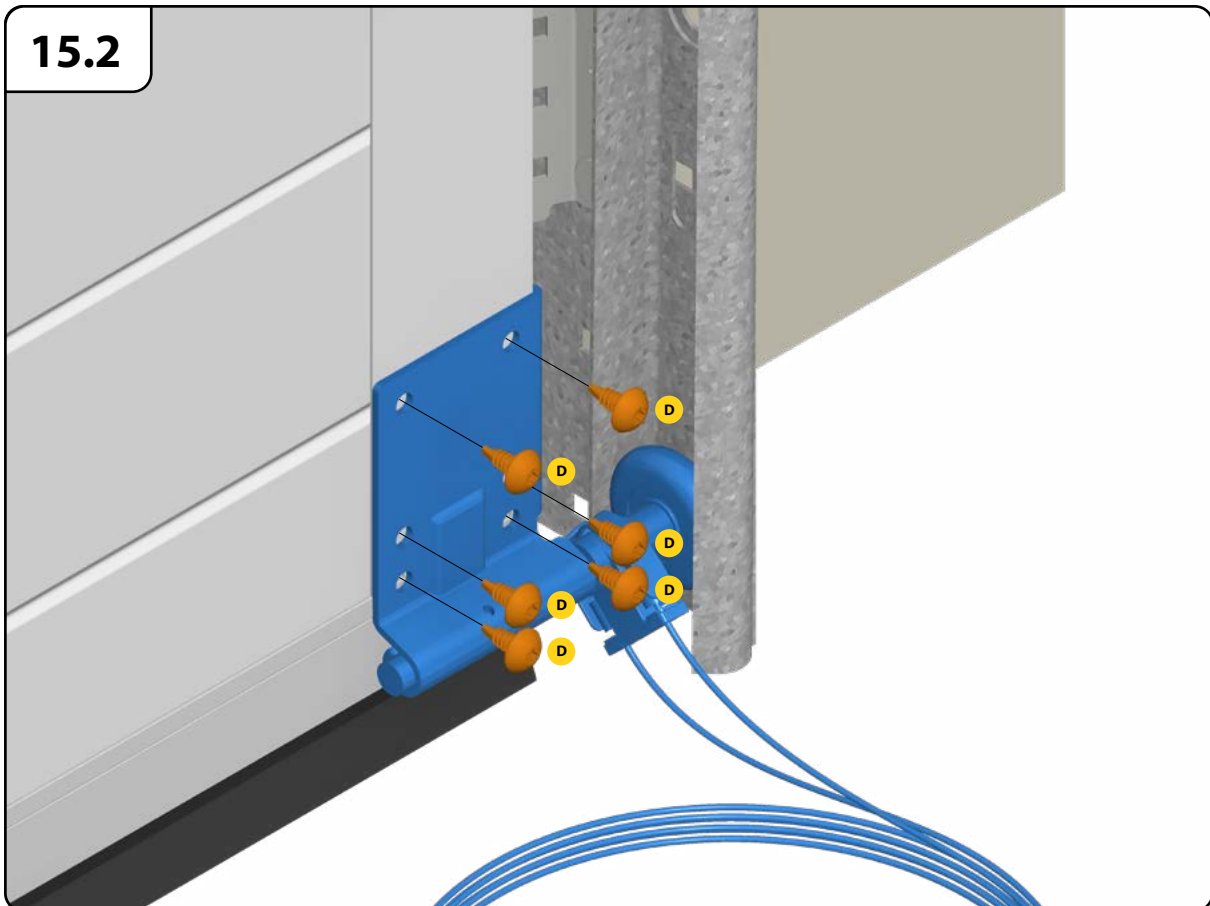

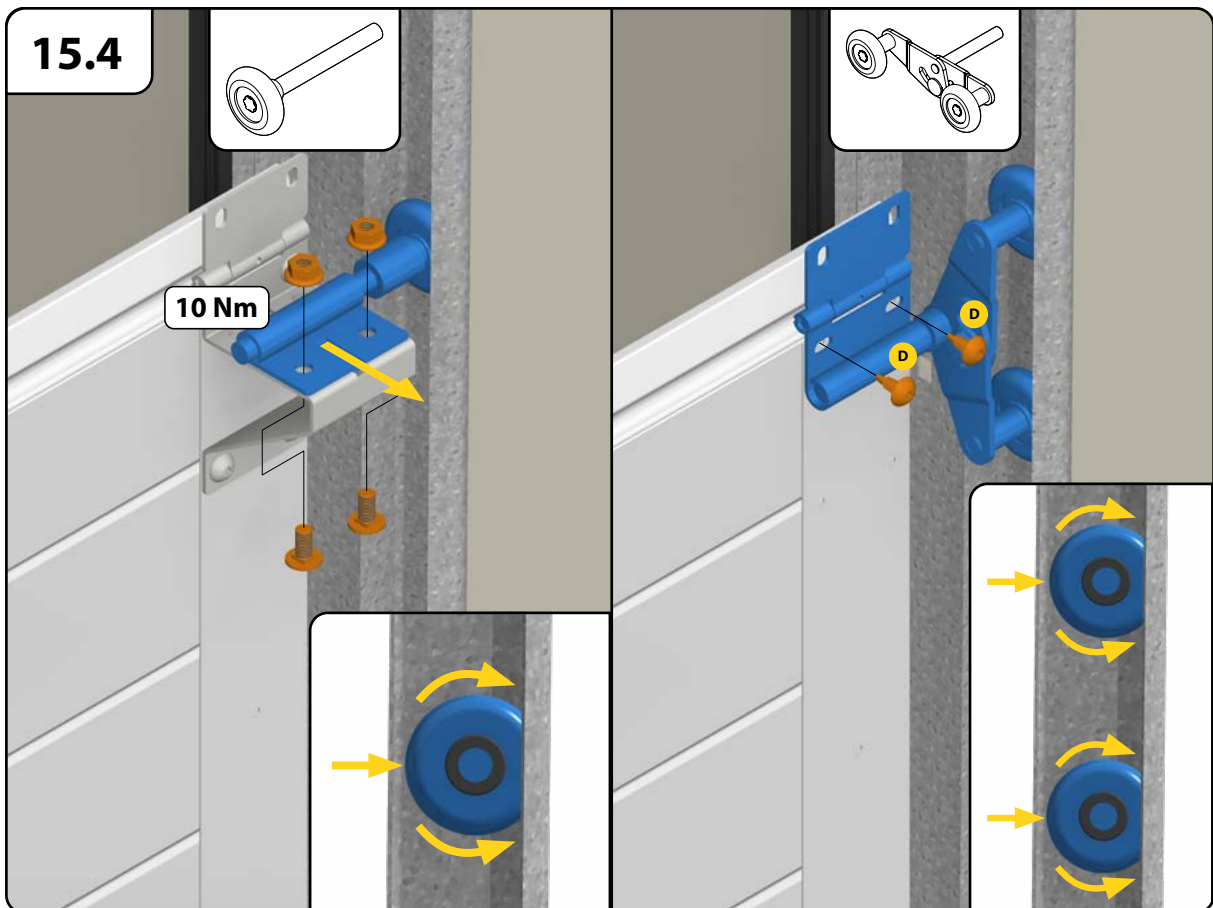
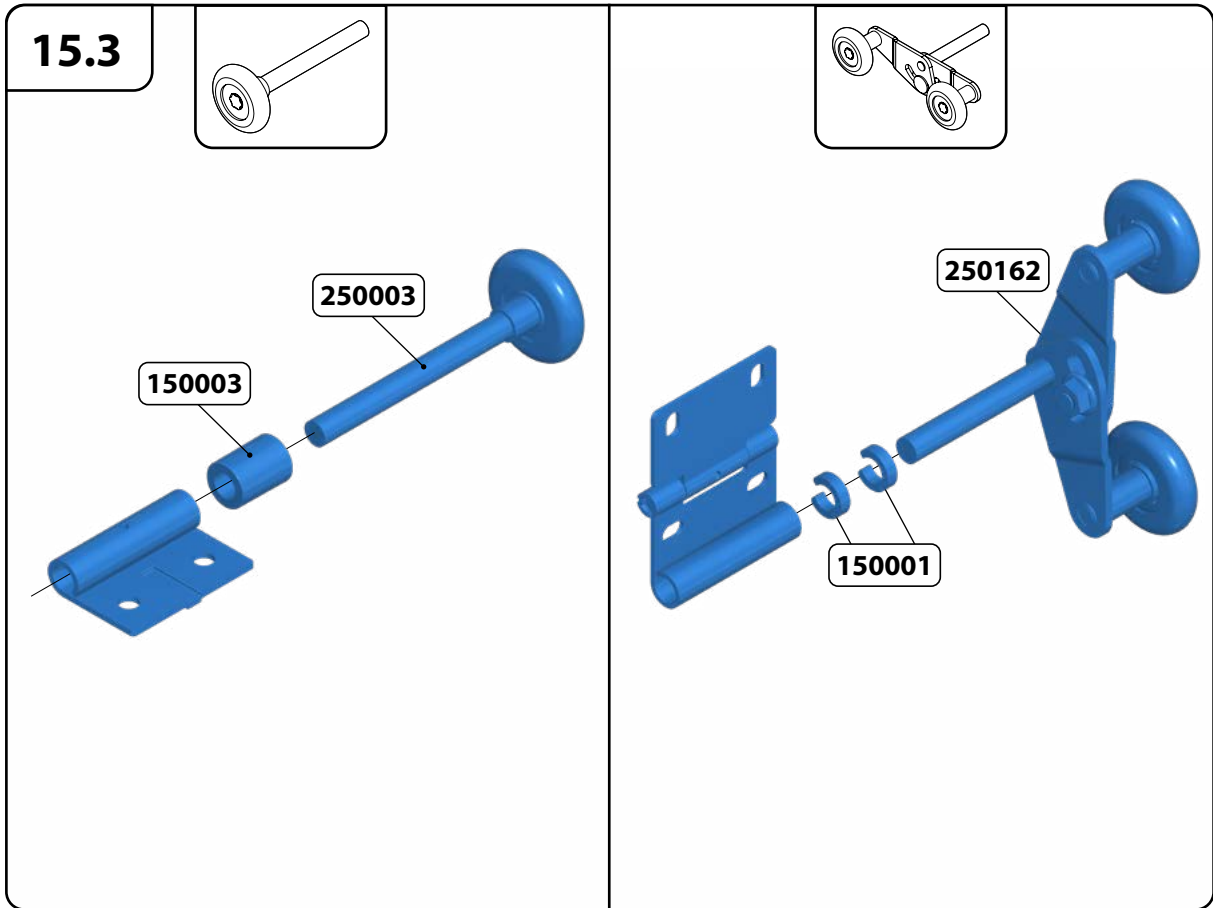

16

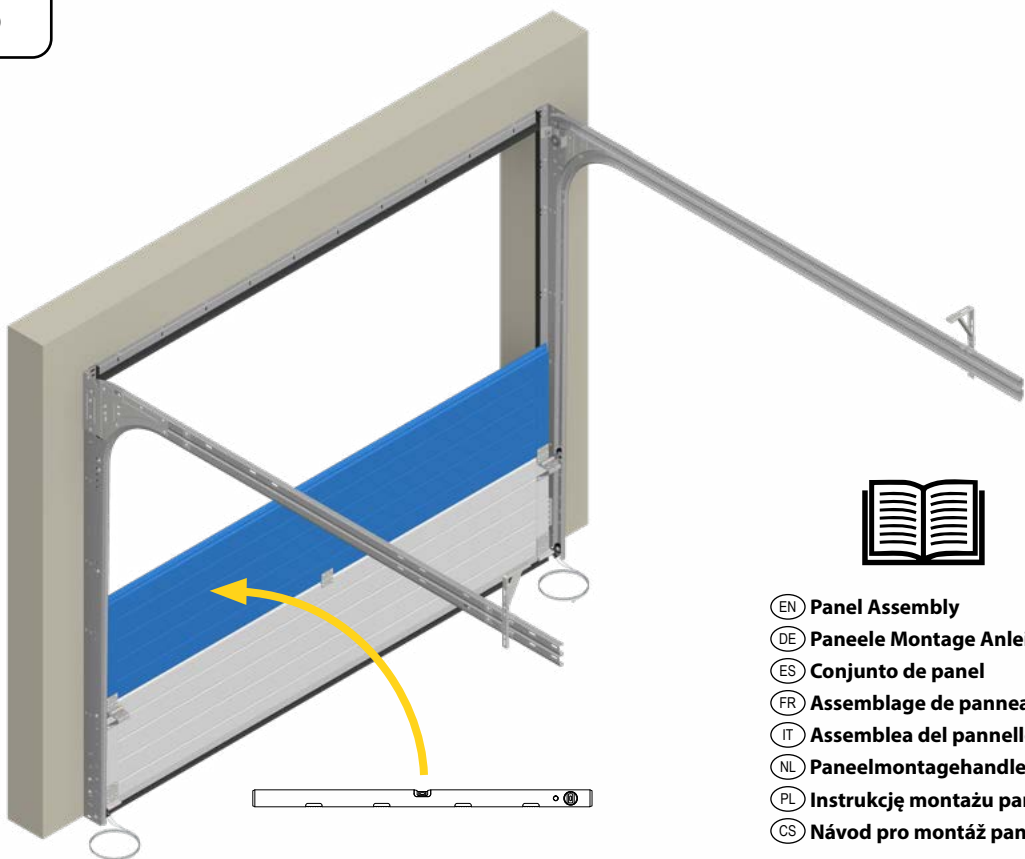

- Ⓔ Panel Assembly
- Ⓓ Paneele Montage Anleitung
- Ⓔ Conjunto de panel
- Ⓕ Assemblage de panneau
- Ⓘ Assembla del pannello
- Ⓓ Paneelmontagehandleiding
- Ⓓ Instrukcję montażu paneli
- Ⓒ Návod pro montáž panelů

16.1

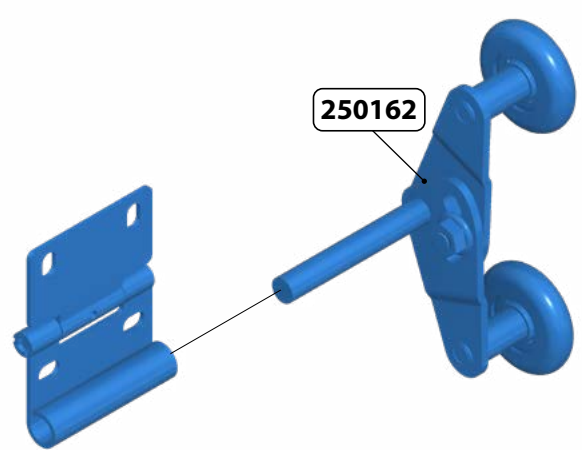
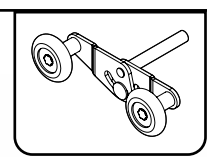
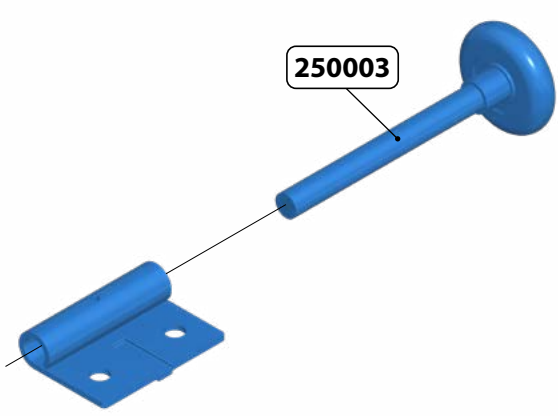
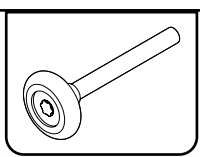

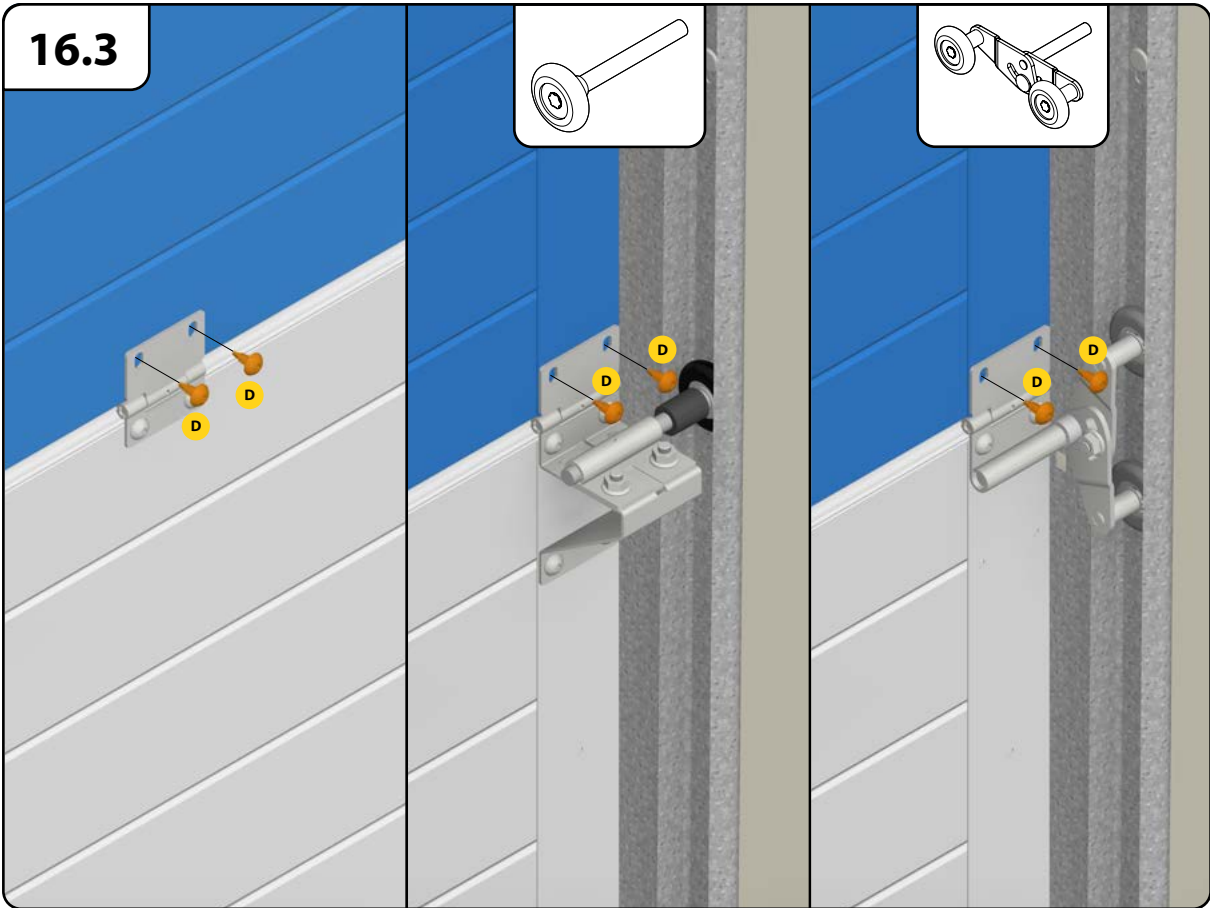
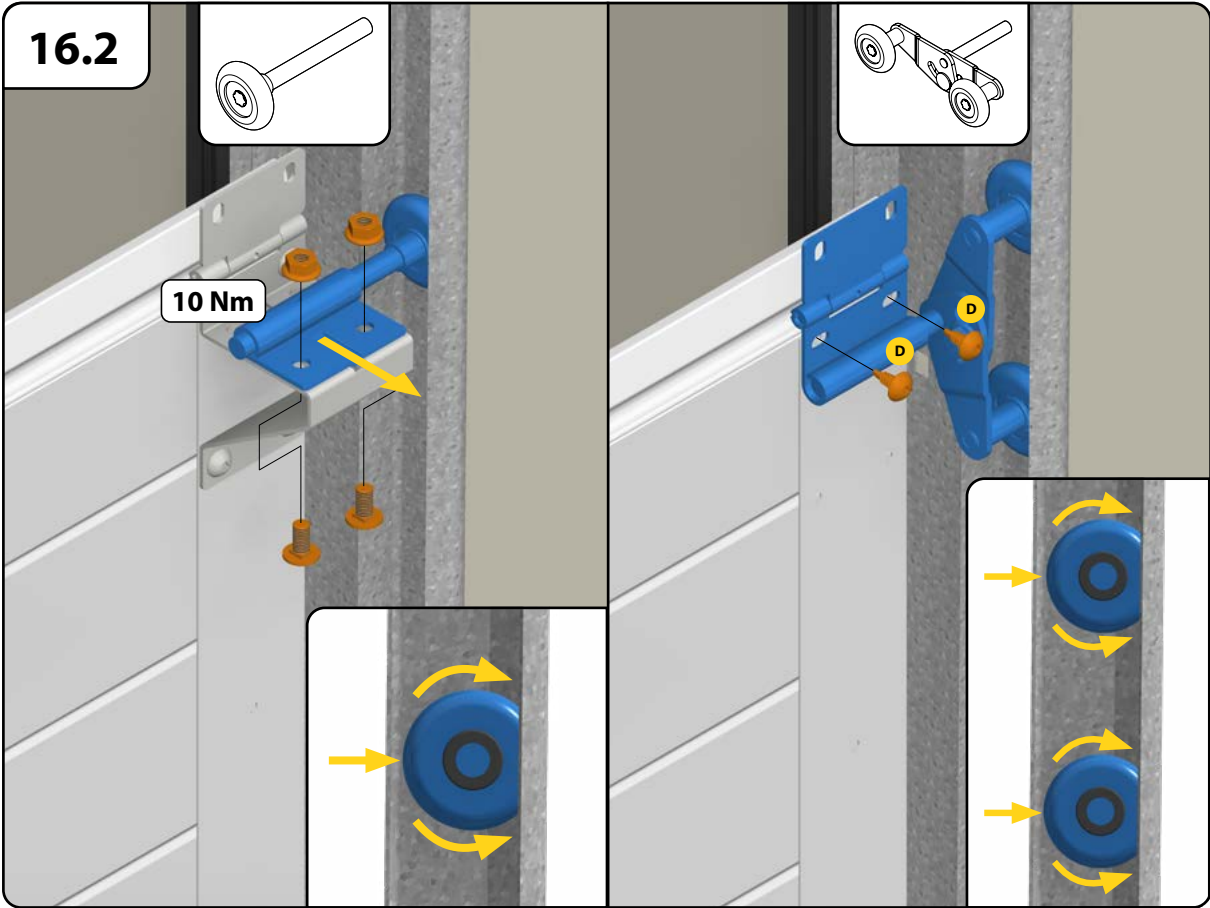

17

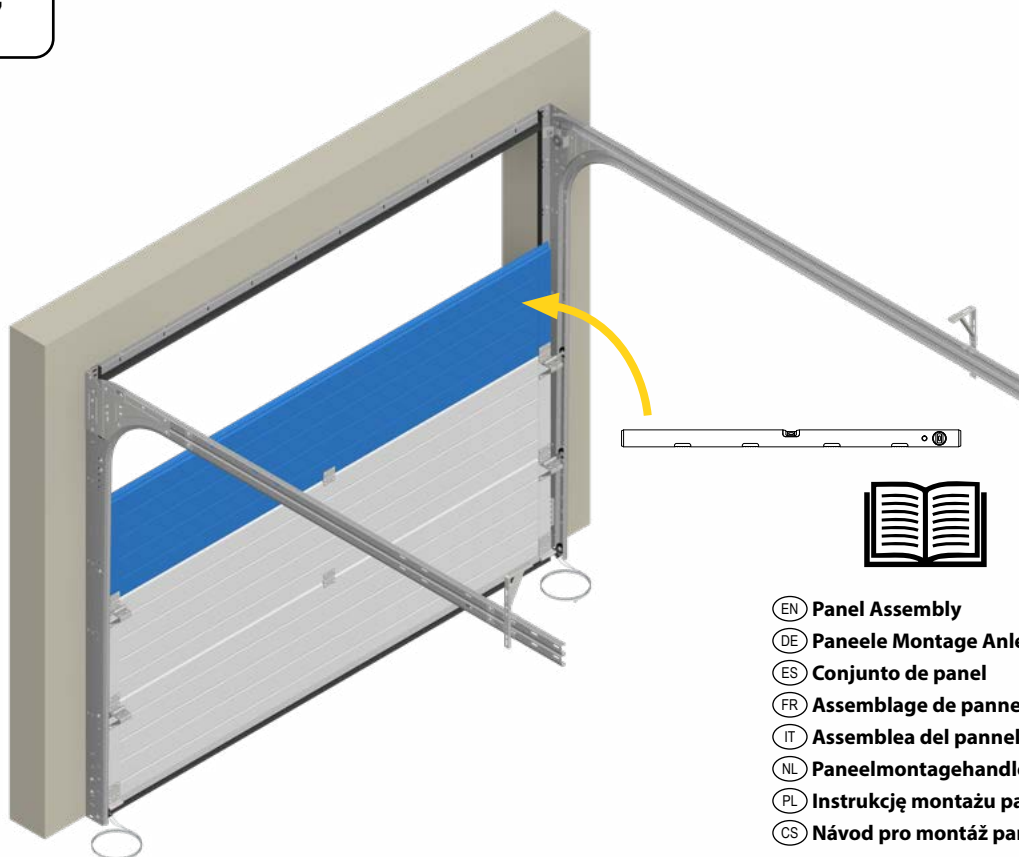

- (EN) Panel Assembly
- (DE) Paneele Montage Anleitung
- (ES) Conjunto de panel
- (FR) Assemblage de panneau
- (IT) Assembla del pannello
- (NL) Paneelmontagehandleiding
- (PL) Instrukcję montażu paneli
- (CS) Návod pro montáž panelů

17.1

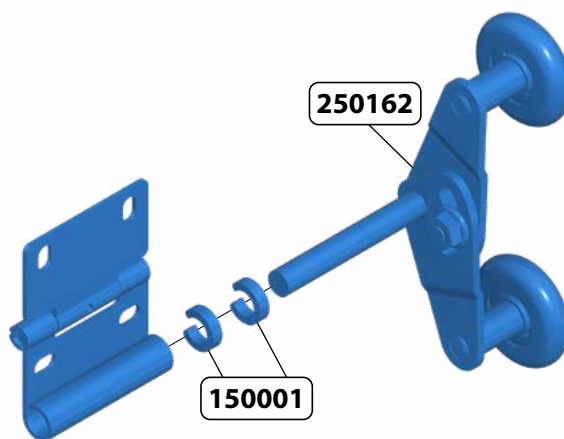
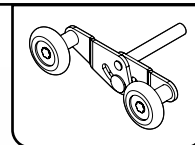
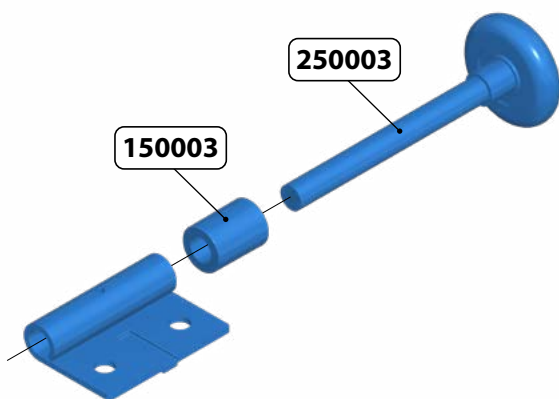
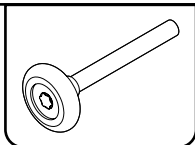

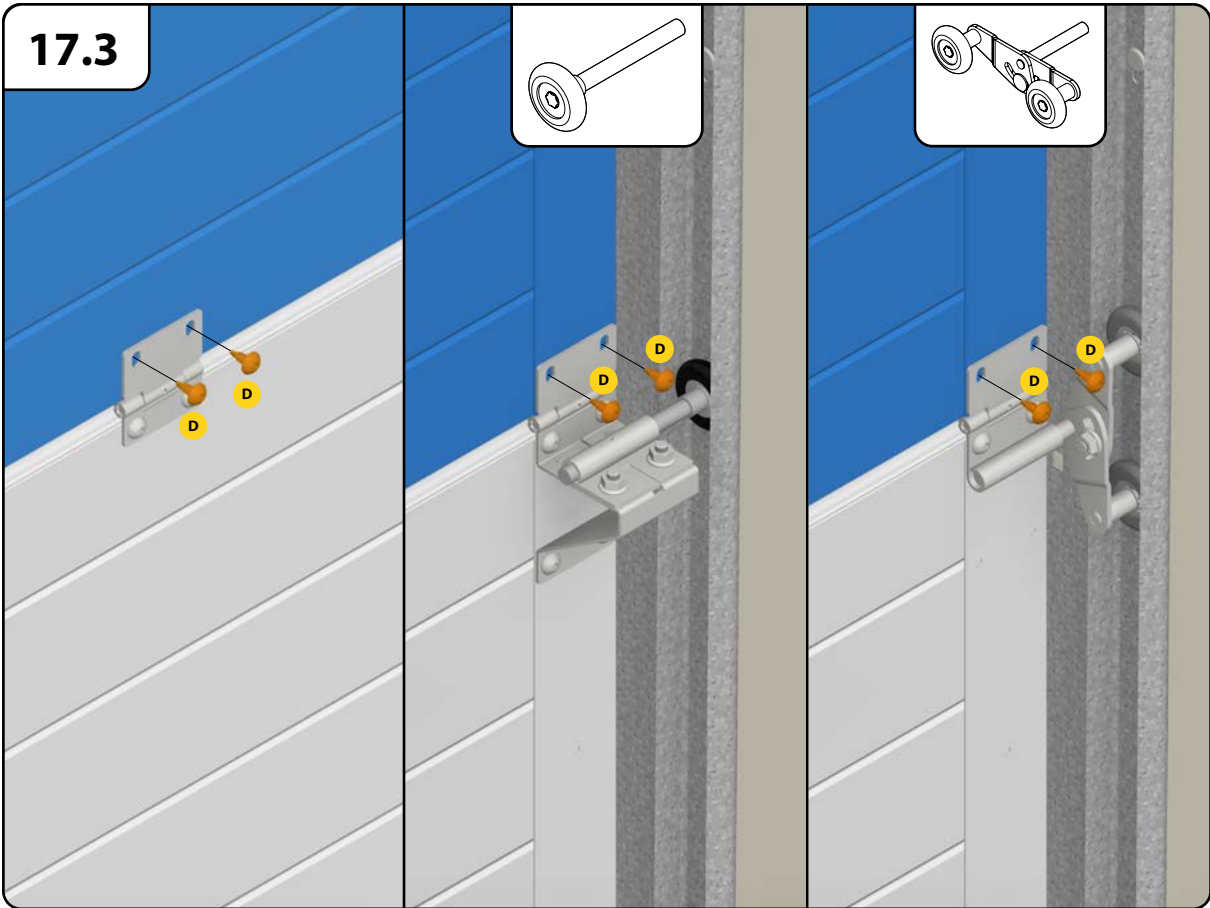
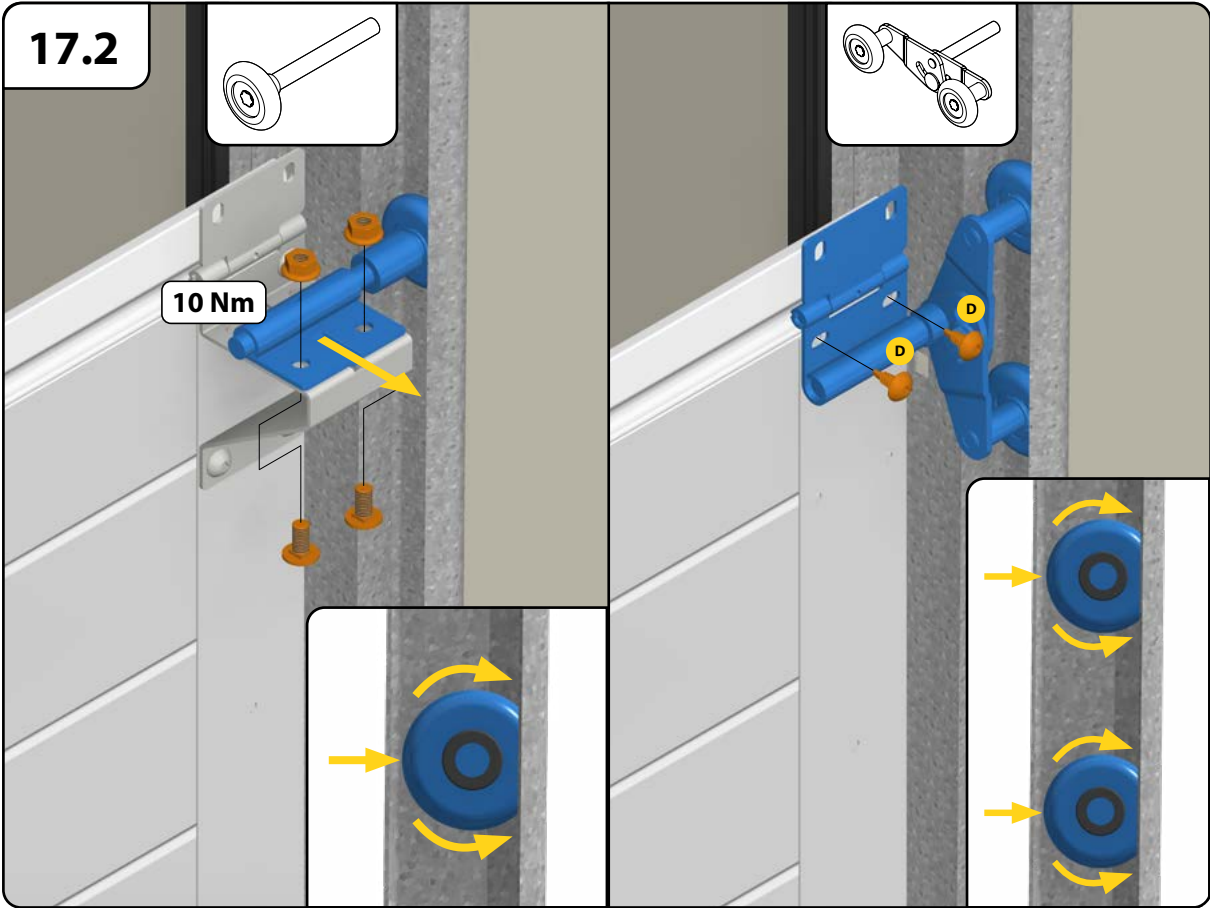

18

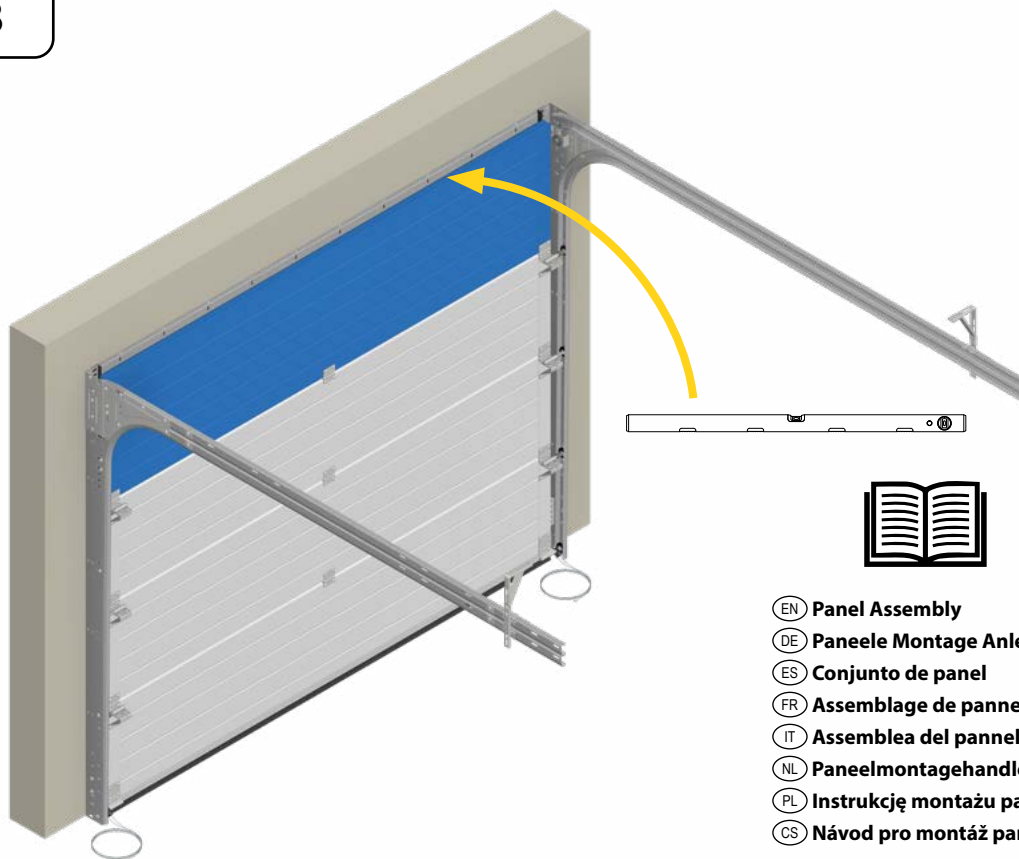

- (EN) Panel Assembly
- (DE) Paneele Montage Anleitung
- (ES) Conjunto de panel
- (FR) Assemblage de panneau
- (IT) Assembla del pannello
- (NL) Paneelmontagehandleiding
- (PL) Instrukcję montażu paneli
- (CS) Návod pro montáž panelů

18.1

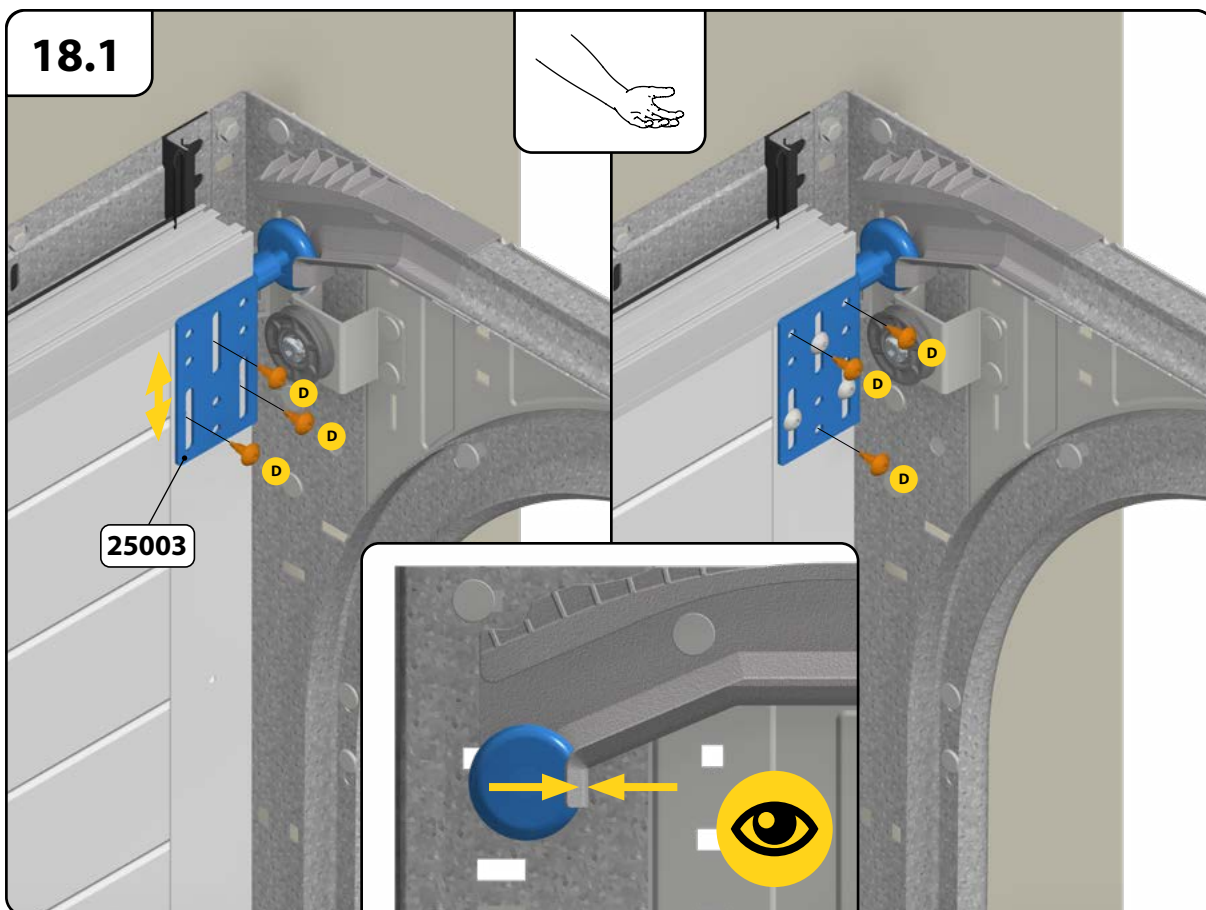

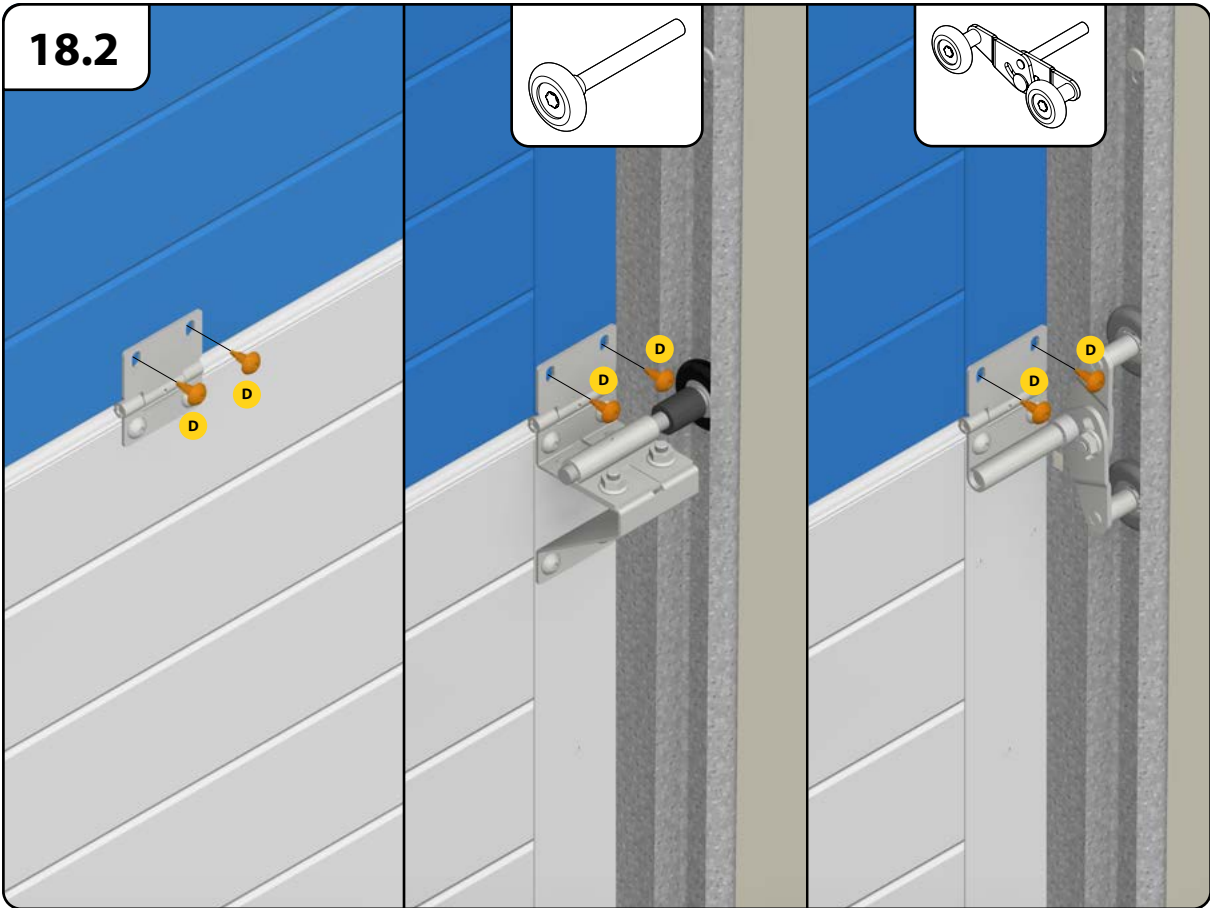
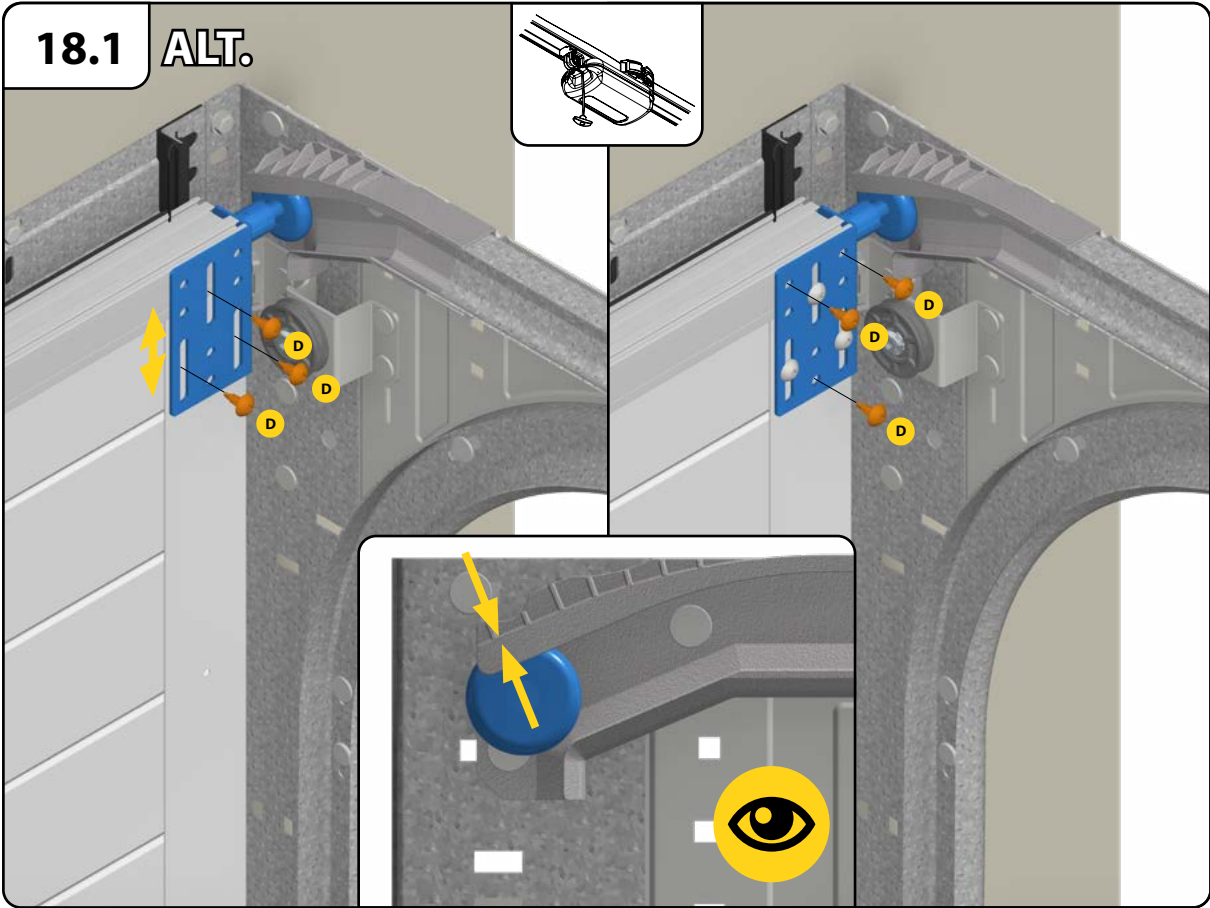

19

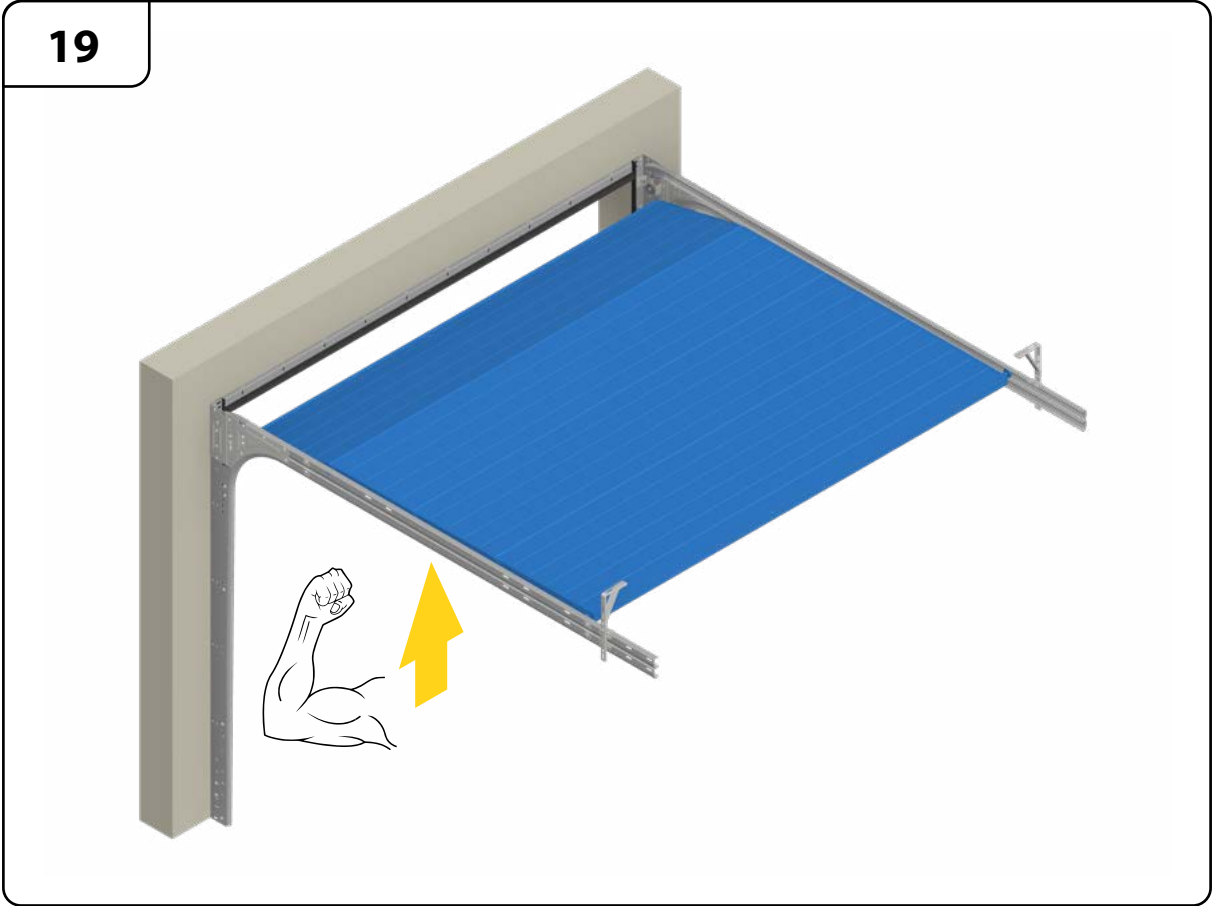

19.1

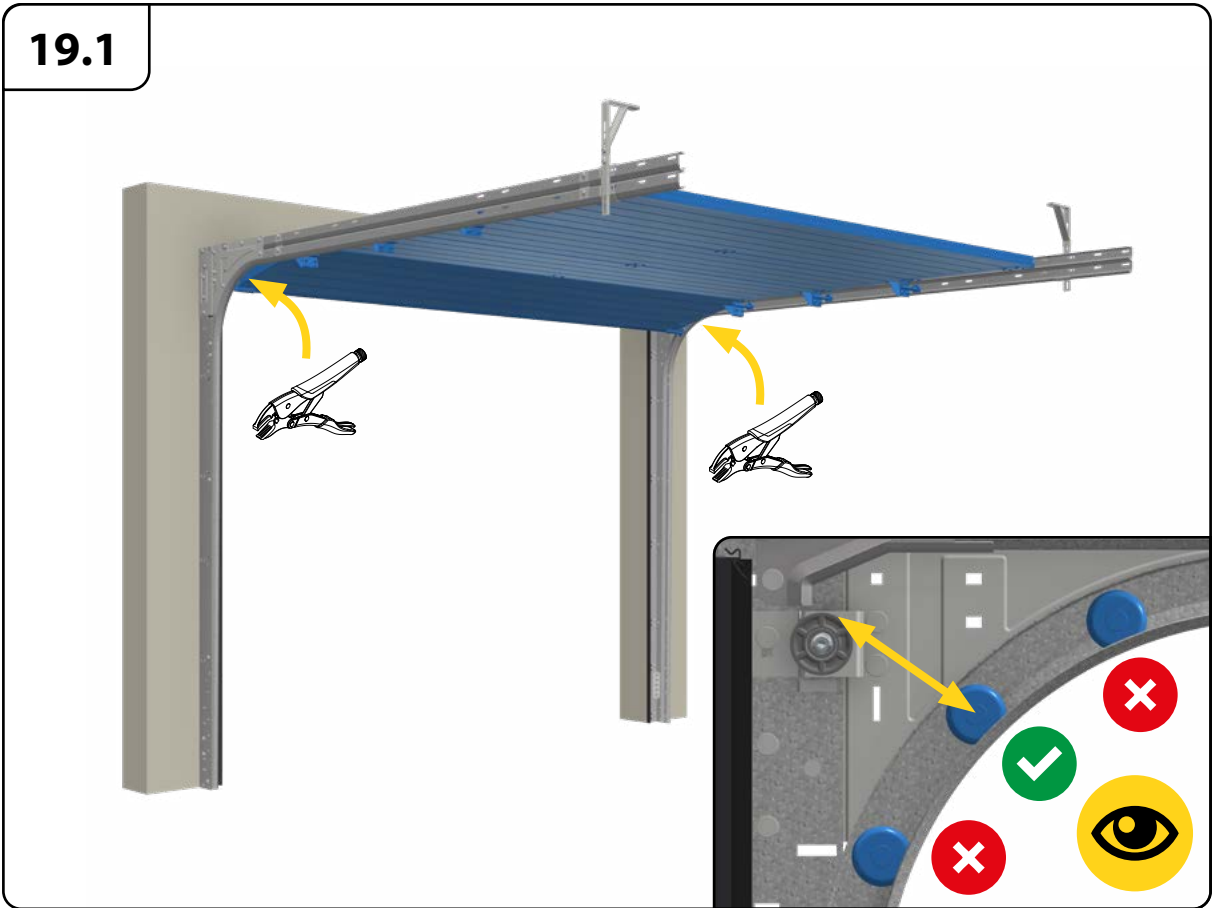

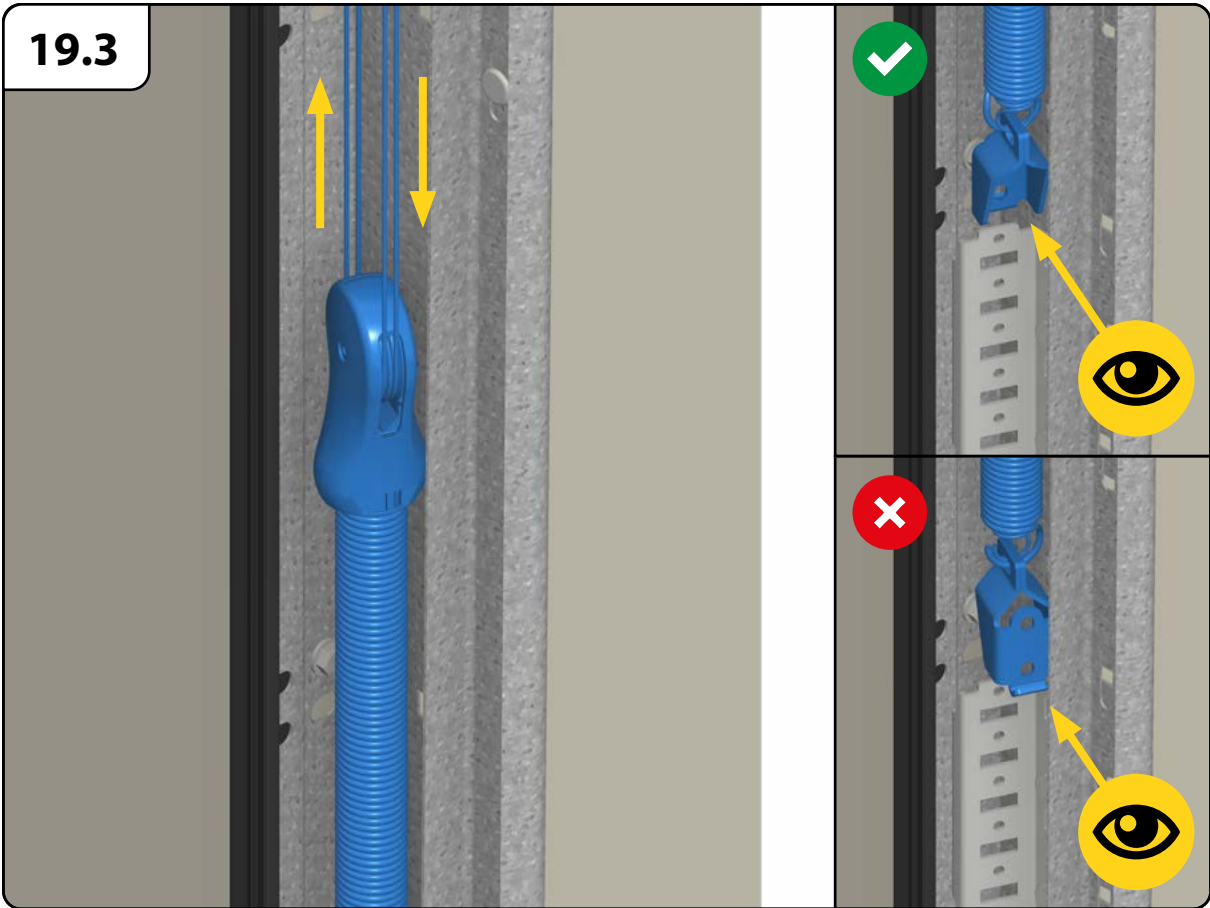
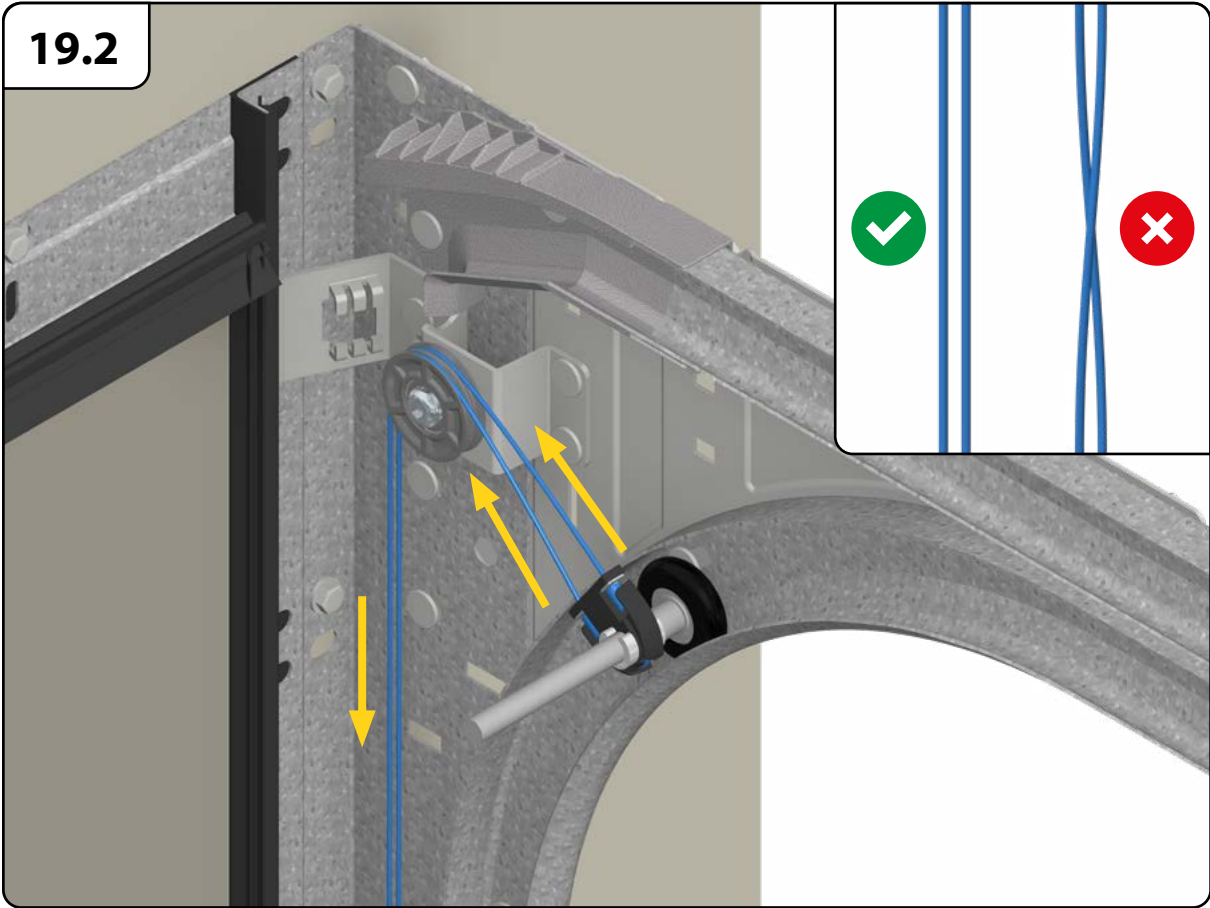

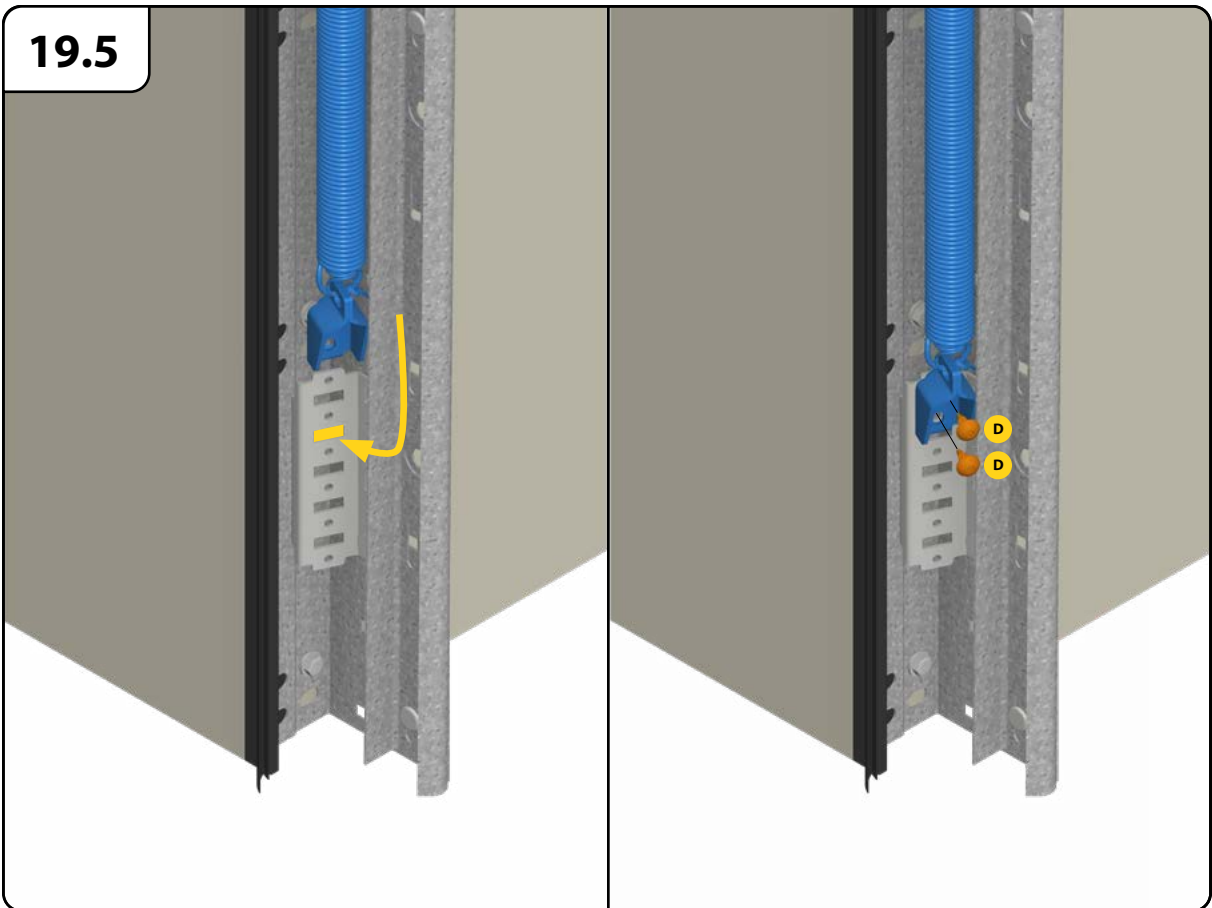
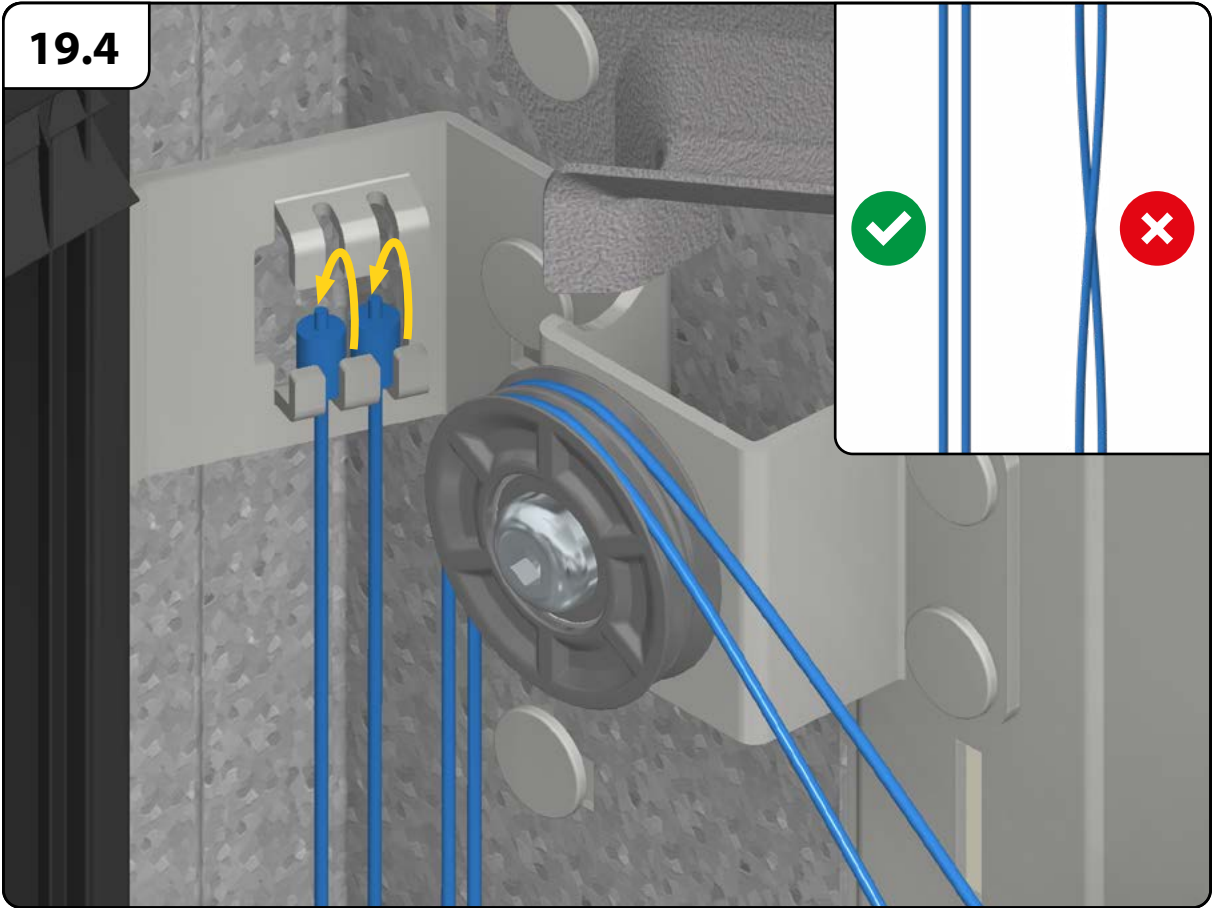

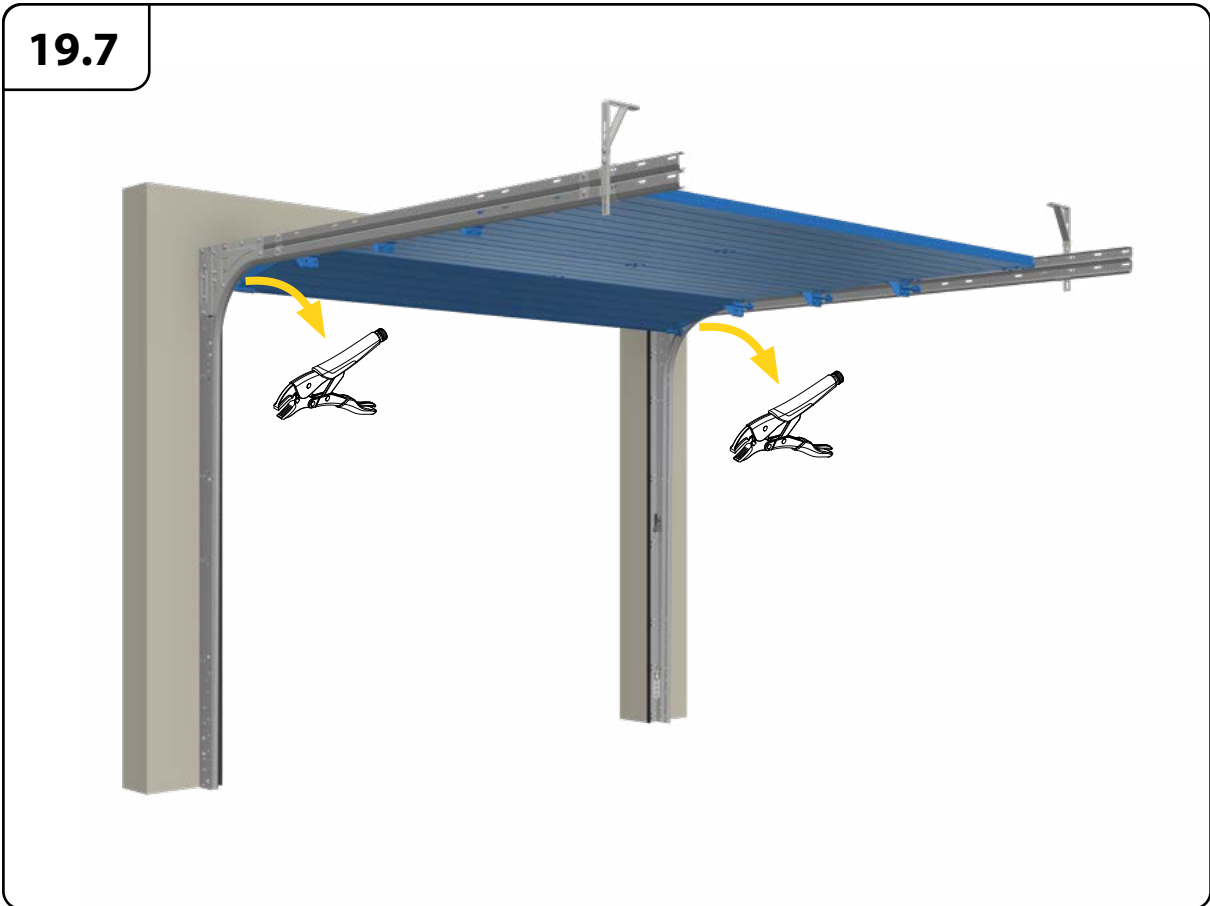
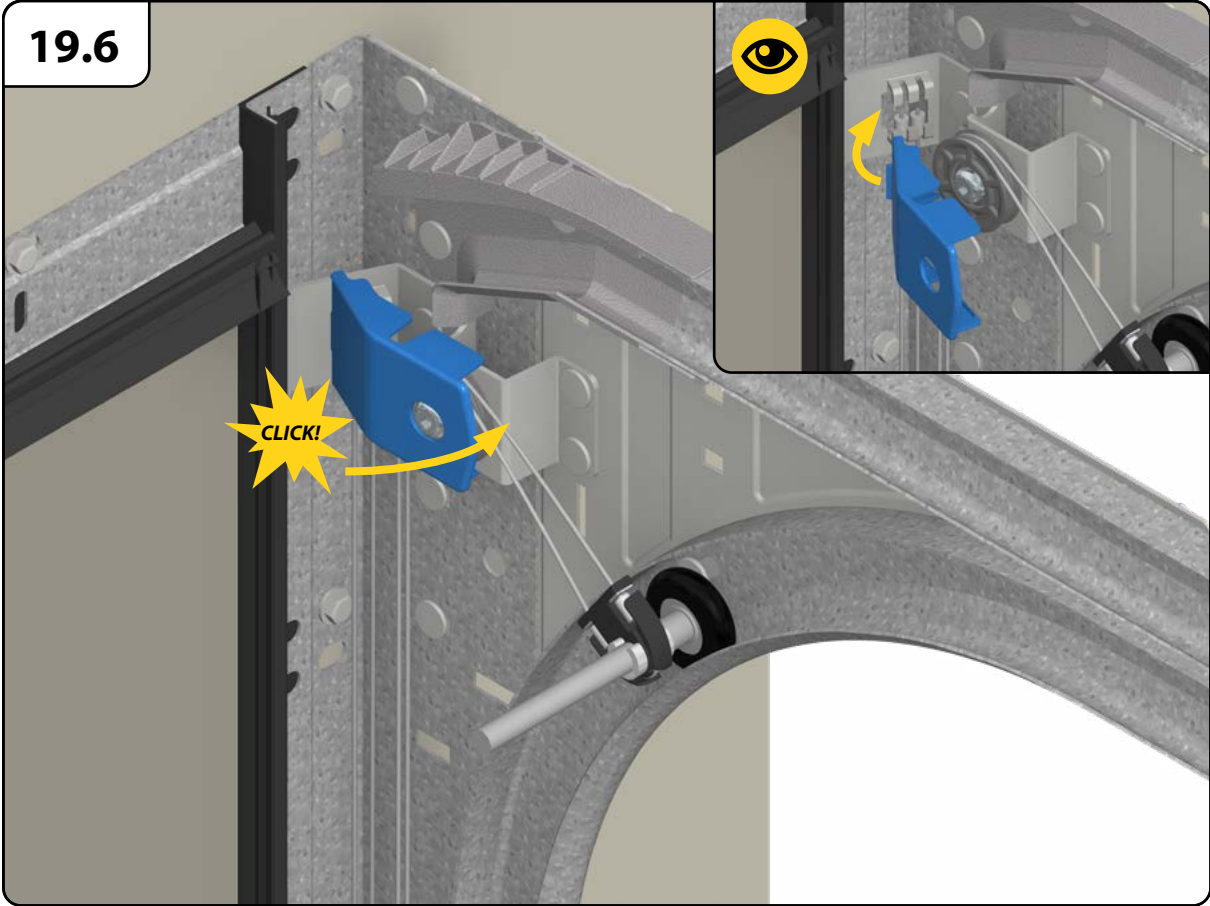

19.8

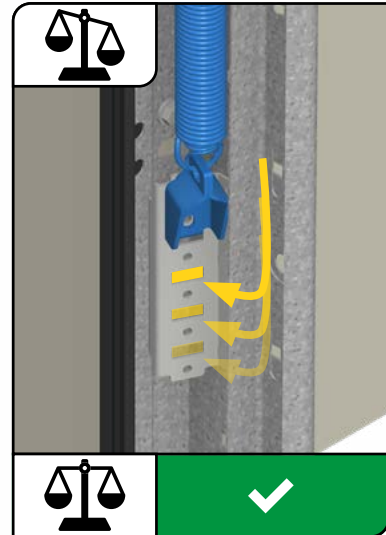
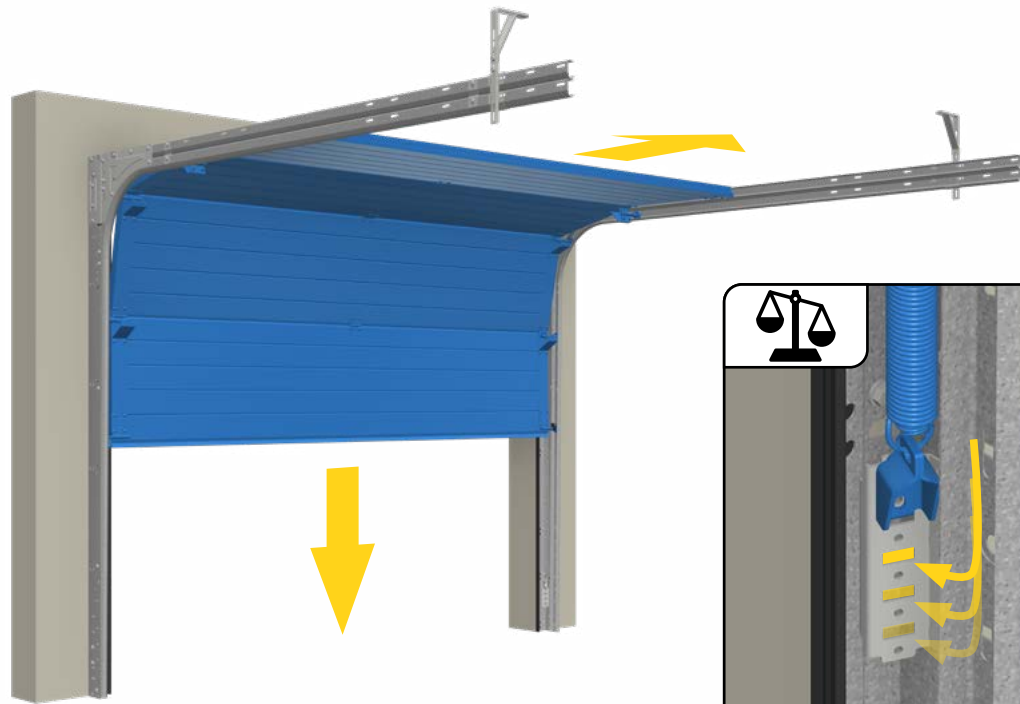

20

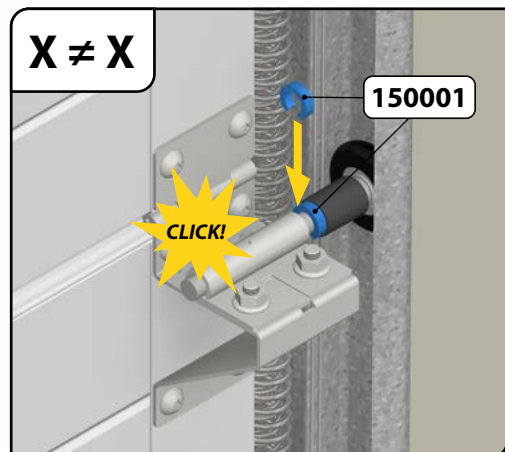
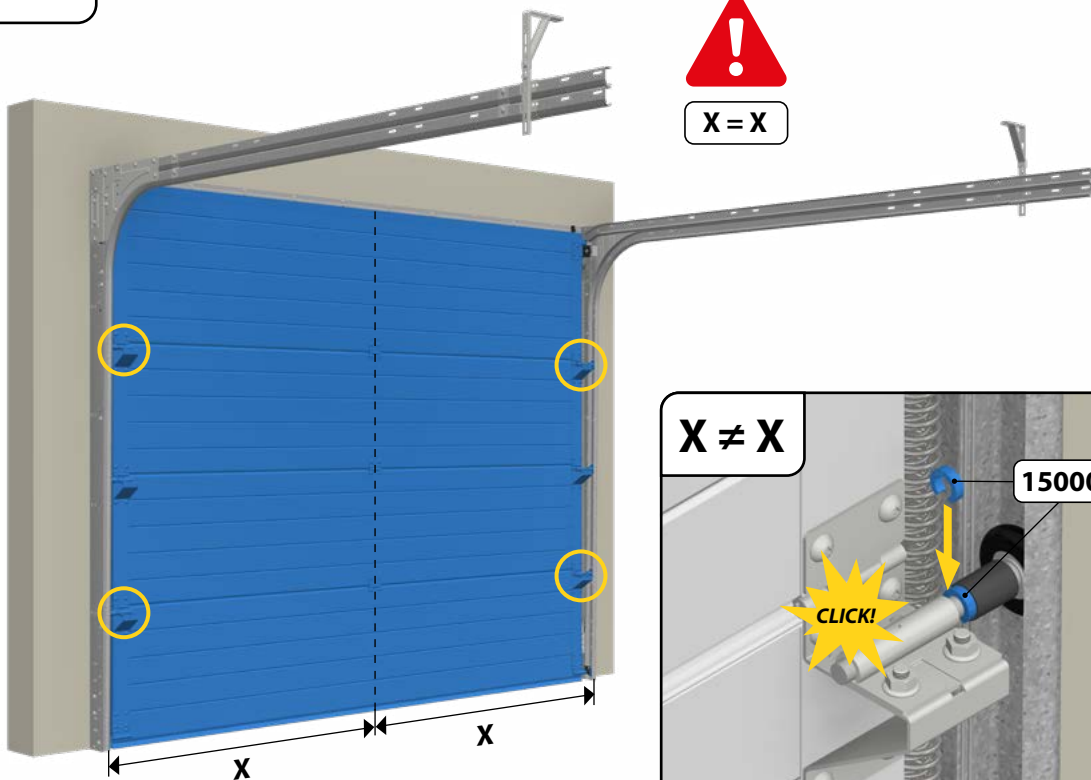

21

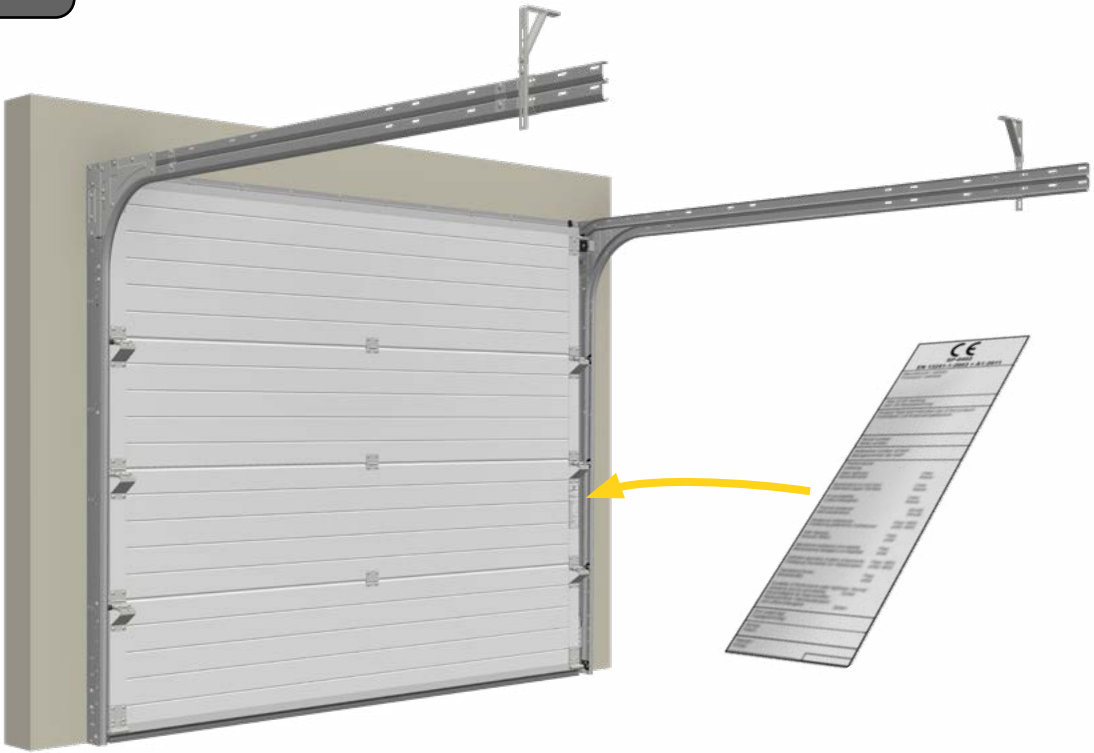

22

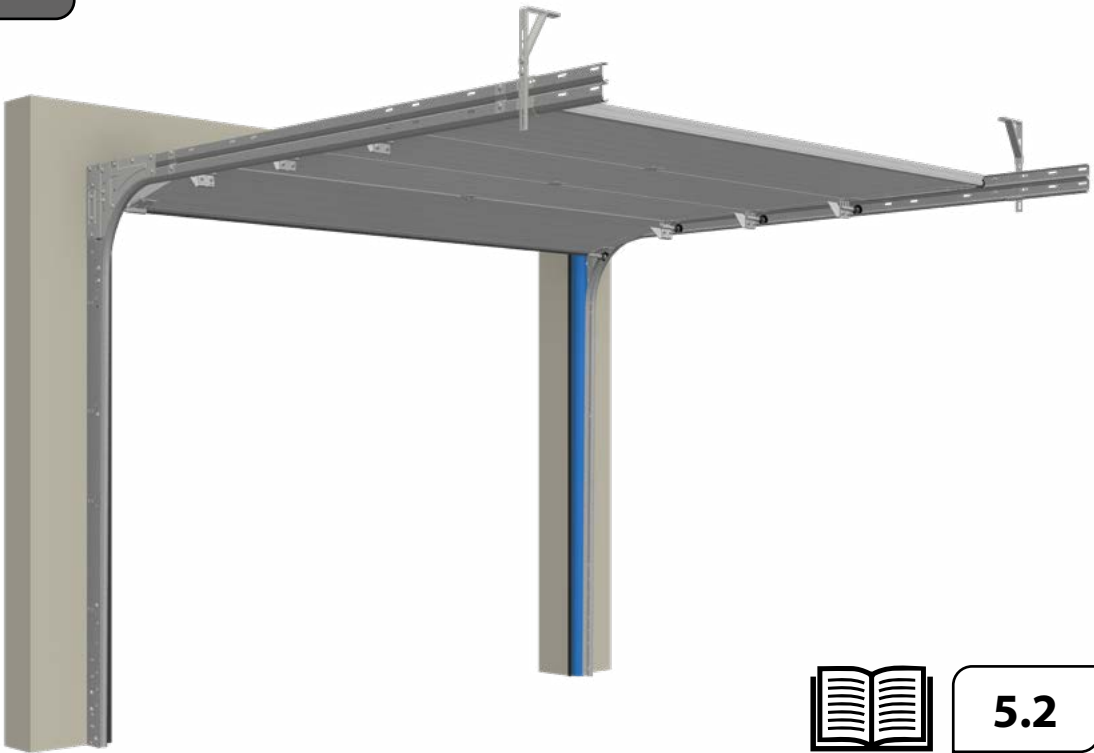

5.2

HOME-X

